

NOTES: UNLESS OTHERWISE SPECIFIED

- 1 MATERIAL: MATERIAL SPECIFIED AT INDIVIDUAL PART LEVEL
- 2 ALL DIMENSIONS ARE TO THEORETICAL SHARP.
- 3 REMOVE BURRS AND BREAK ALL SHARP EDGES .03 MAX.
- 4 ALL DIMENSIONS ARE IN INCHES UNLESS STATED OTHERWISE.
- 5 PARTS SHALL BE FREE OF GREASE AND CUTTING FLUID.
- 6 POWDER COAT PER MIL-PRF-24712A (TYPE 3, CLASS 3)

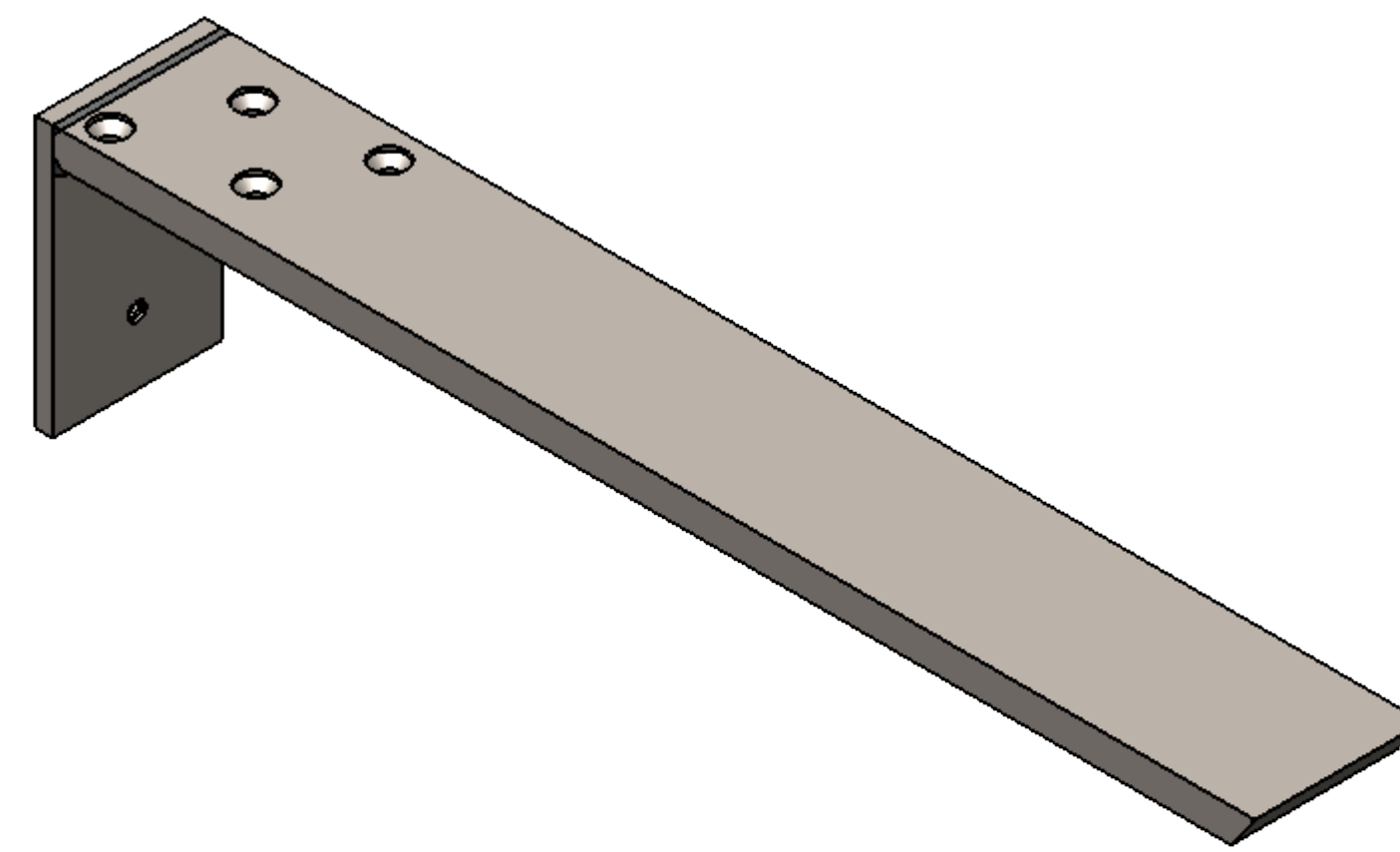

ISOMETRIC VIEW
FOR REFERENCE ONLY

REVISIONS				
ZONE	REV.	DESCRIPTION	DATE	APPROVED
	X1	DEVELOPMENT	03/13/2017	KRH

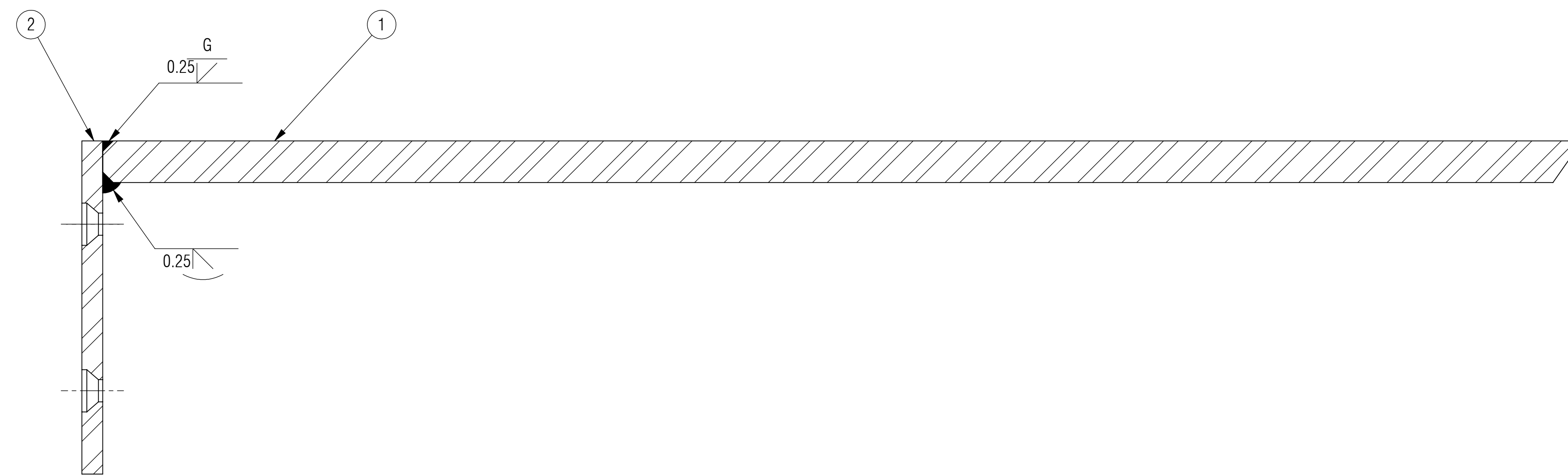
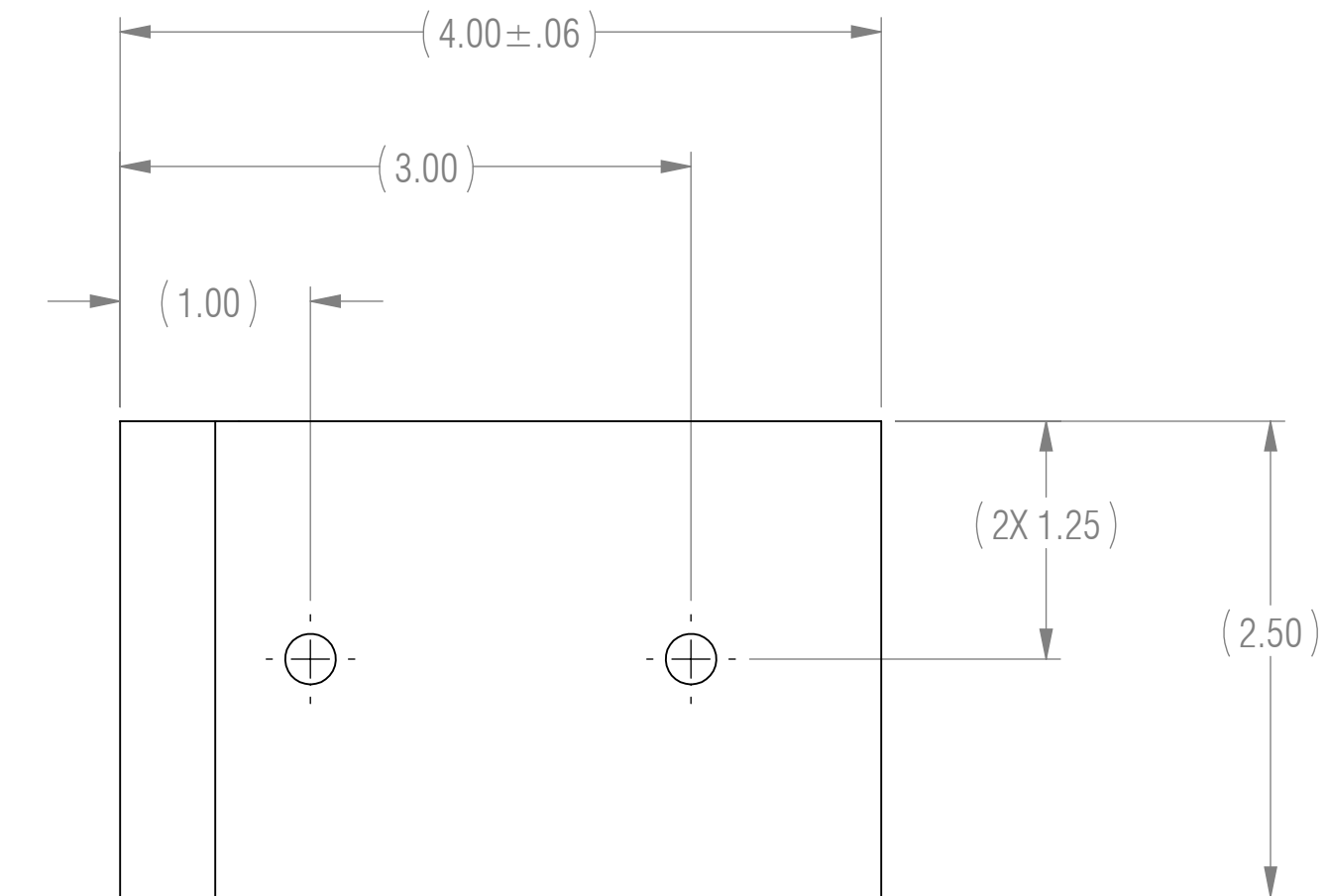

SECTION A-A

RELEASED

BOM TABLE			
ITEM NO.	PART NUMBER	DESCRIPTION	QTY.
1	H14H-17.75	HORIZONTAL SUPPORT, 1 ANGLE, 4 HOLES, 17.75 LENGTH	1
2	A-FL	FL FLANGE	1

<p>UNLESS OTHERWISE SPECIFIED: DIMENSIONS ARE IN INCHES</p> <p>TOLERANCES ARE:</p> <table border="0"> <tr> <td>.XX ± .01</td> <td>ANGLES</td> </tr> <tr> <td>.XXX ± .005</td> <td>XX° ± 1°</td> </tr> </table>	.XX ± .01	ANGLES	.XXX ± .005	XX° ± 1°	<table border="1"> <tr><td>ENGINEER</td><td></td><td></td></tr> <tr><td>ENGINEER</td><td></td><td></td></tr> <tr><td>ENGINEER</td><td></td><td></td></tr> <tr><td>CHECKED</td><td>CAS</td><td>03/13/2017</td></tr> <tr><td>DRAWN</td><td>KRH</td><td>03/13/2017</td></tr> <tr><td colspan="3">MANAGER APPROVAL</td></tr> </table>	ENGINEER			ENGINEER			ENGINEER			CHECKED	CAS	03/13/2017	DRAWN	KRH	03/13/2017	MANAGER APPROVAL			<p>Centerline Brackets</p>
	.XX ± .01	ANGLES																						
	.XXX ± .005	XX° ± 1°																						
	ENGINEER																							
ENGINEER																								
ENGINEER																								
CHECKED	CAS	03/13/2017																						
DRAWN	KRH	03/13/2017																						
MANAGER APPROVAL																								
<p>INTERPRET DRAWINGS IN ACCORDANCE WITH:</p> <p>ASME Y14.100 ENGINEERING DRAWING PRACTICES ASME Y14.38 ABBREVIATIONS ASME Y14.5 DIMENSIONING AND TOLERANCING ASME Y14.6 SCREW THREAD REPRESENTATION ASME Y14.8 CASTINGS, FORGINGS & MOLDED PARTS AWS A2.4 WELDING SYMBOLS IEEE STD 315 SYMBOLS FOR ELECTRICAL AND ELECTRONIC DIAGRAMS</p>	<p>THE INFORMATION ON THIS DRAWING IS PROPRIETARY AND SHALL NOT BE DISCLOSED, USED, OR DUPLICATED FOR PROCUREMENT OR MANUFACTURING PURPOSES WITHOUT THE EXPRESS WRITTEN CONSENT OF CENTERLINE STEEL, LLC</p>	<p>DRAWING TITLE</p> <p>FORWARD L BRACKET</p>																						
<p>USED ON</p> <p>APPLICATION</p>	<p>THIRD ANGLE PROJECTION</p>	<table border="1"> <tr> <td>SIZE</td> <td>CAGE CODE</td> <td>DRAWING NO.</td> <td>REV</td> </tr> <tr> <td>D</td> <td></td> <td>FLB-18</td> <td>X1</td> </tr> </table>	SIZE	CAGE CODE	DRAWING NO.	REV	D		FLB-18	X1														
SIZE	CAGE CODE	DRAWING NO.	REV																					
D		FLB-18	X1																					
		<p>SCALE 1:1</p> <p>SHEET 1 OF 1</p>																						