

NOTES: UNLESS OTHERWISE SPECIFIED

- 1 MATERIAL: MATERIAL SPECIFIED AT INDIVIDUAL PART LEVEL
- 2 ALL DIMENSIONS ARE TO THEORETICAL SHARP.
- 3 REMOVE BURRS AND BREAK ALL SHARP EDGES .03 MAX.
- 4 ALL DIMENSIONS ARE IN INCHES UNLESS STATED OTHERWISE.
- 5 PARTS SHALL BE FREE OF GREASE AND CUTTING FLUID.
- 6 POWDER COAT PER MIL-PRF-24712A (TYPE 3, CLASS 3)

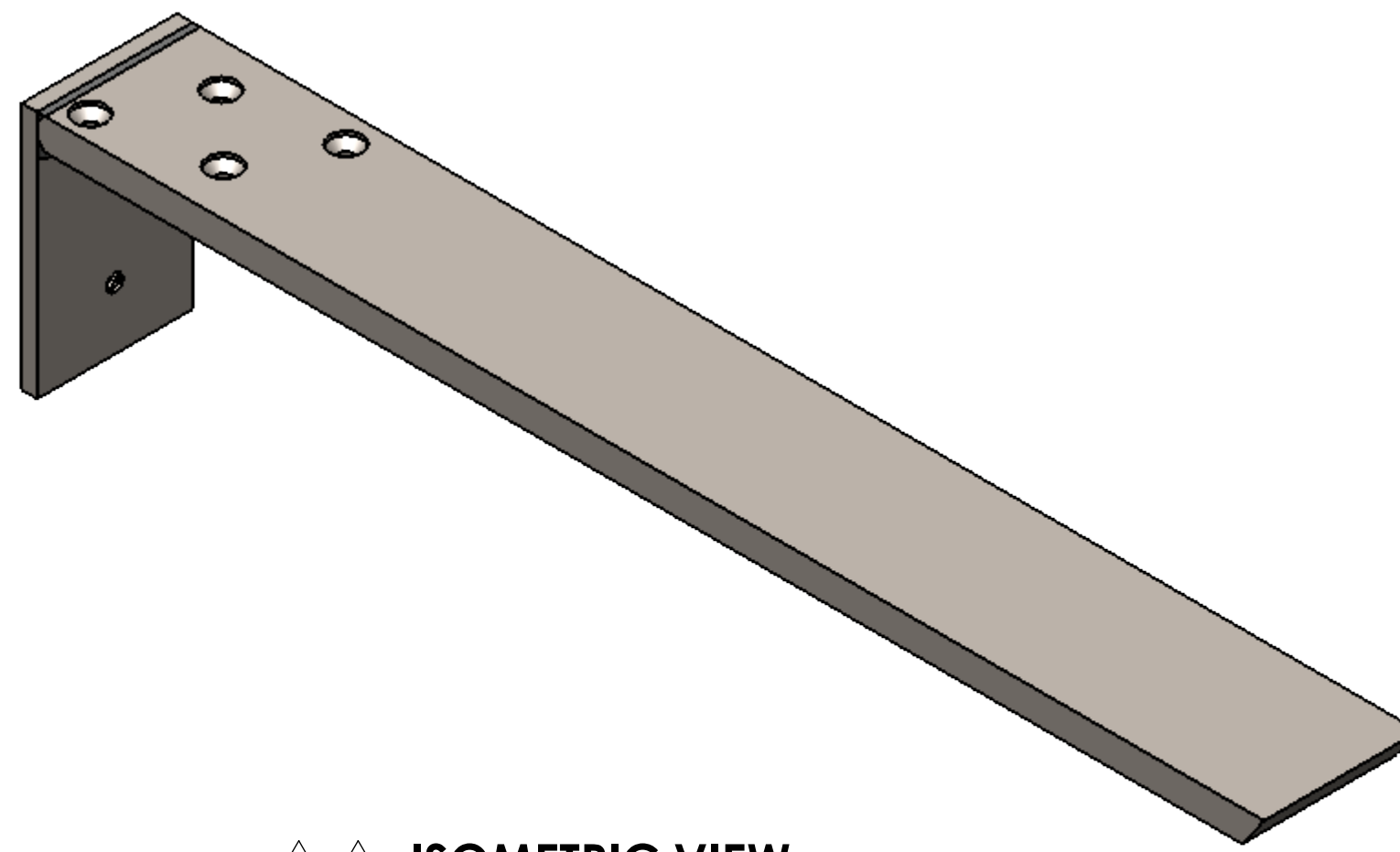

ISOMETRIC VIEW
FOR REFERENCE ONLY

REVISIONS				
ZONE	REV.	DESCRIPTION	DATE	APPROVED
	X1	DEVELOPMENT	03/13/2017	KRH

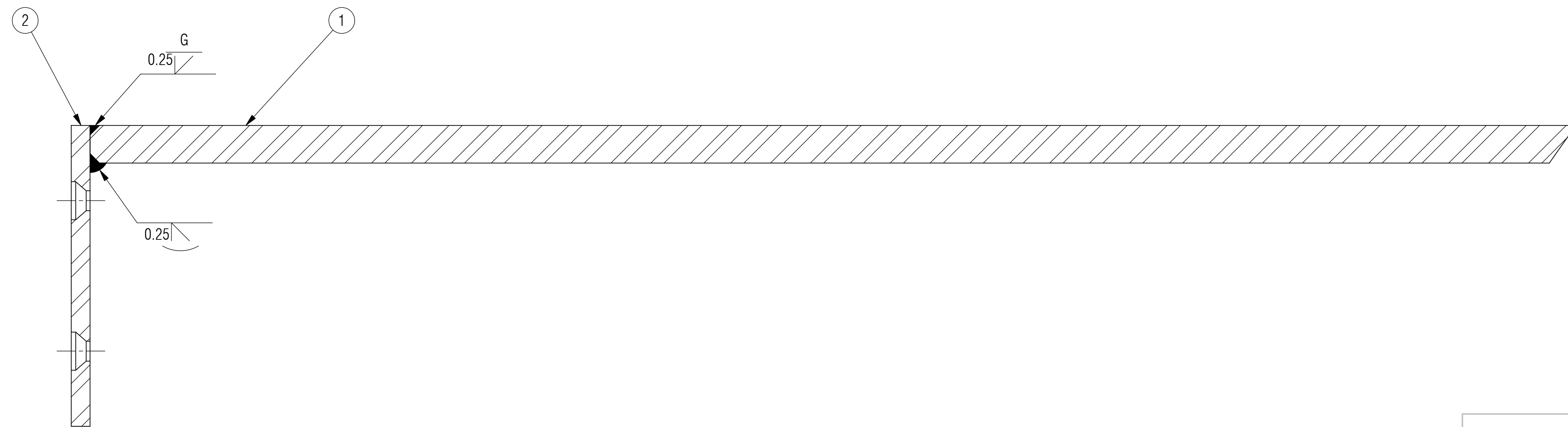
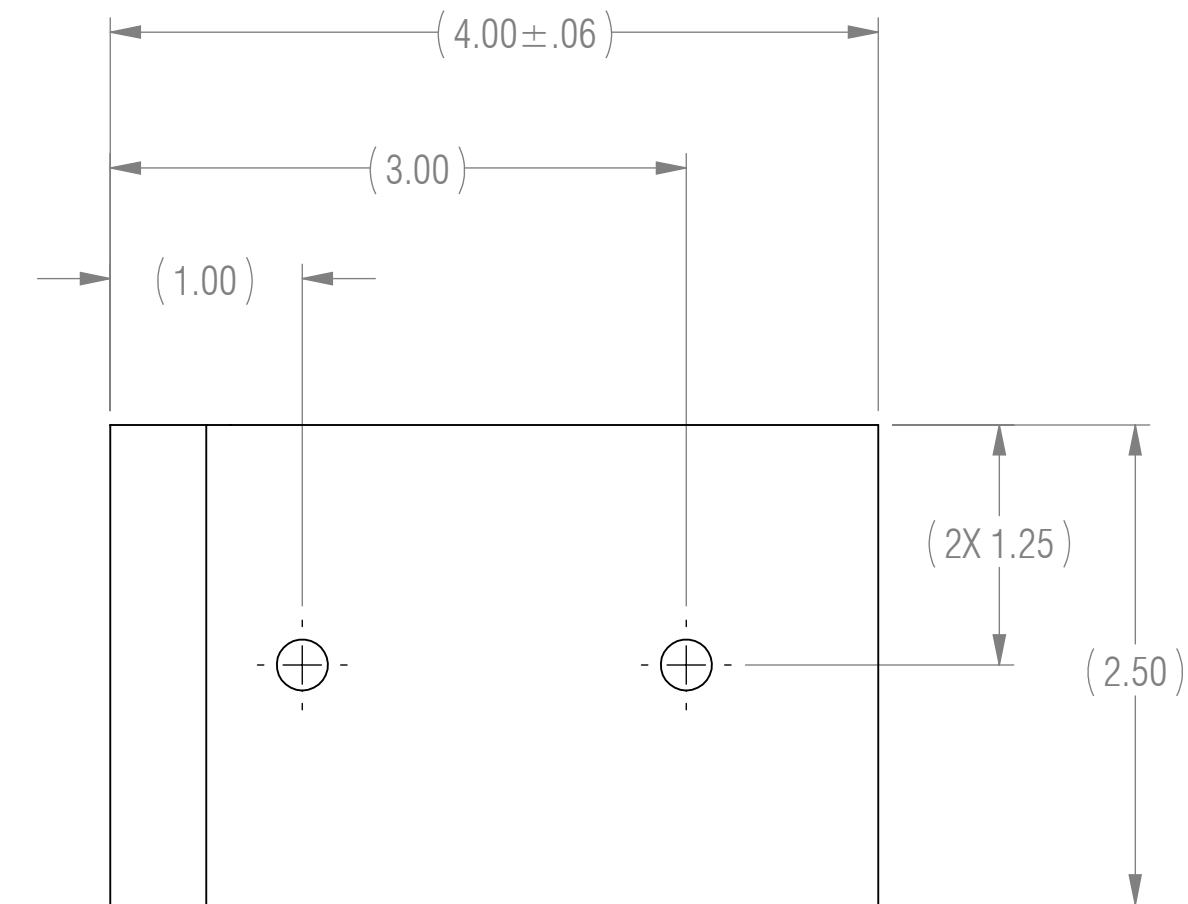
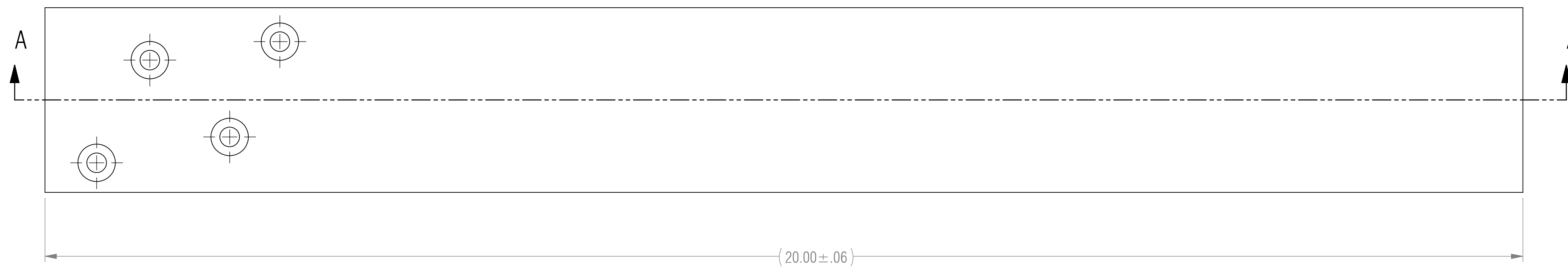

SECTION A-A

RELEASED

BOM TABLE			
ITEM NO.	PART NUMBER	DESCRIPTION	QTY.
1	H14H-19.75	HORIZONTAL SUPPORT, 1 ANGLE, 4 HOLES, 19.75 LENGTH	1
2	A-FL	FL FLANGE	1

UNLESS OTHERWISE SPECIFIED: DIMENSIONS ARE IN INCHES		ENGINEER		
TOLERANCES ARE:		ENGINEER		
.XX ± .01	ANGLES	ENGINEER		
.XXX ± .005	XX° ± 1°	CHECKED CAS	03/13/2017	
		DRAWN KRH	03/13/2017	
INTERPRET DRAWINGS IN ACCORDANCE WITH:		MANAGER APPROVAL		
ASME Y14.100	ENGINEERING DRAWING PRACTICES	THE INFORMATION ON THIS DRAWING IS PROPRIETARY AND SHALL NOT BE DISCLOSED, USED, OR DUPLICATED FOR PROCUREMENT OR MANUFACTURING PURPOSES WITHOUT THE EXPRESS WRITTEN CONSENT OF CENTERLINE STEEL, LLC		
ASME Y14.38	ABBREVIATIONS			
ASME Y14.5	DIMENSIONING AND TOLERANCING			
ASME Y14.6	SCREW THREAD REPRESENTATION			
ASME Y14.8	CASTINGS, FORGINGS & MOLDED PARTS			
AWS A2.4	WELDING SYMBOLS	THIRD ANGLE PROJECTION		
IEEE STD 315	SYMBOLS FOR ELECTRICAL AND ELECTRONIC DIAGRAMS			
USED ON APPLICATION				
		DRAWING TITLE		
		FORWARD L BRACKET		
SIZE D	CAGE CODE	DRAWING NO. FLB-20	REV X1	
SCALE 1:1		SHEET 1 OF 1		