

NOTES: UNLESS OTHERWISE SPECIFIED

- 1 MATERIAL: MATERIAL SPECIFIED AT INDIVIDUAL PART LEVEL.
- 2 ALL DIMENSIONS ARE TO THEORETICAL SHARP.
- 3 REMOVE BURRS AND BREAK ALL SHARP EDGES .03 MAX.
- 4 ALL DIMENSIONS ARE IN INCHES UNLESS STATED OTHERWISE.
- 5 PARTS SHALL BE FREE OF GREASE AND CUTTING FLUID.
- 6 POWDER COAT PER MIL-PRF-24712A (TYPE 3, CLASS 3)

REVISIONS				
ZONE	REV.	DESCRIPTION	DATE	APPROVED
	X1	DEVELOPMENT	12/10/2018	KRH

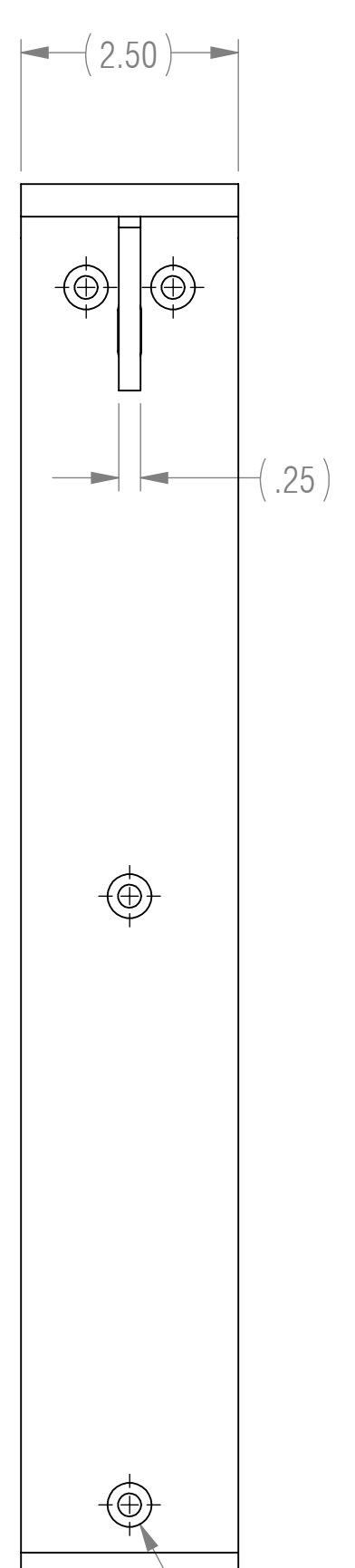

(4X ϕ .27 THRU ALL)
 \checkmark ϕ .51 X 82°
 \square ϕ .51 ∇ .06

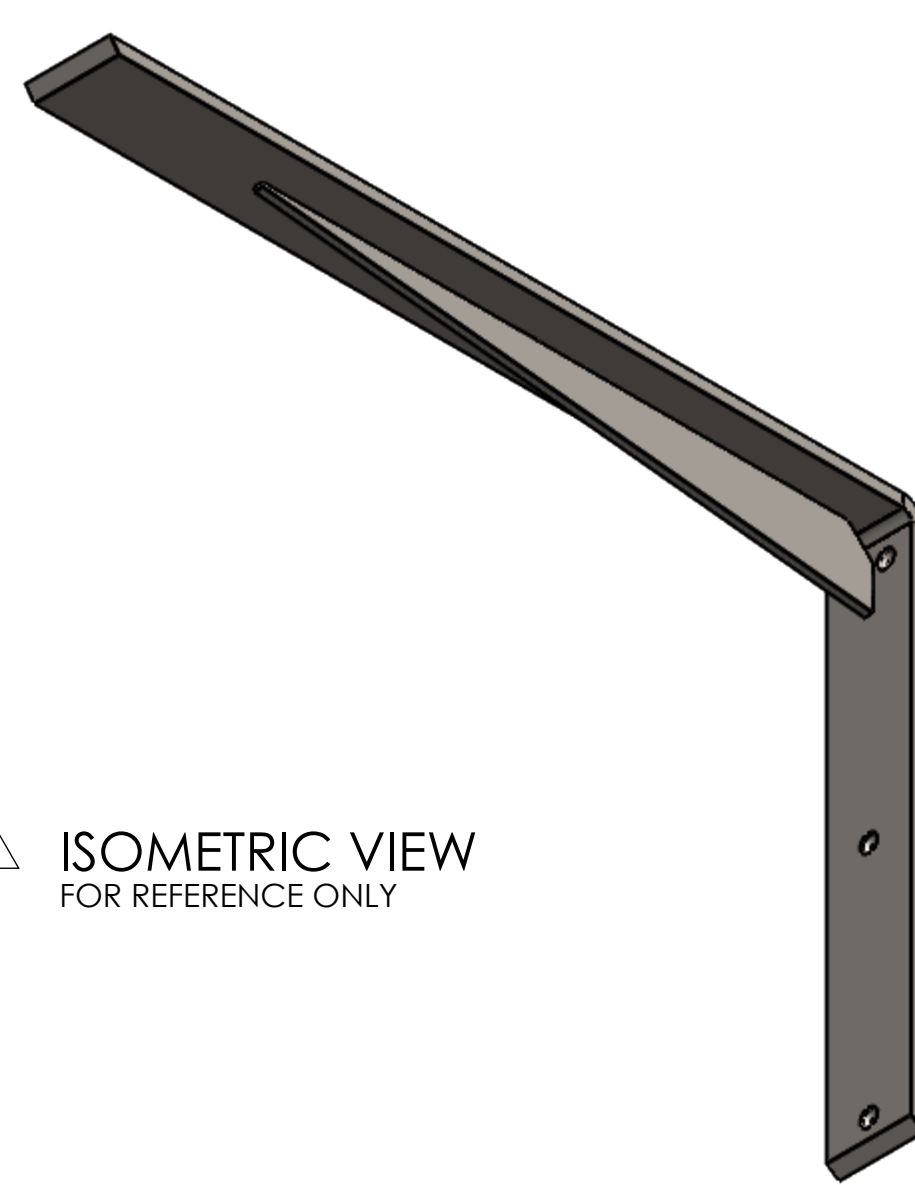
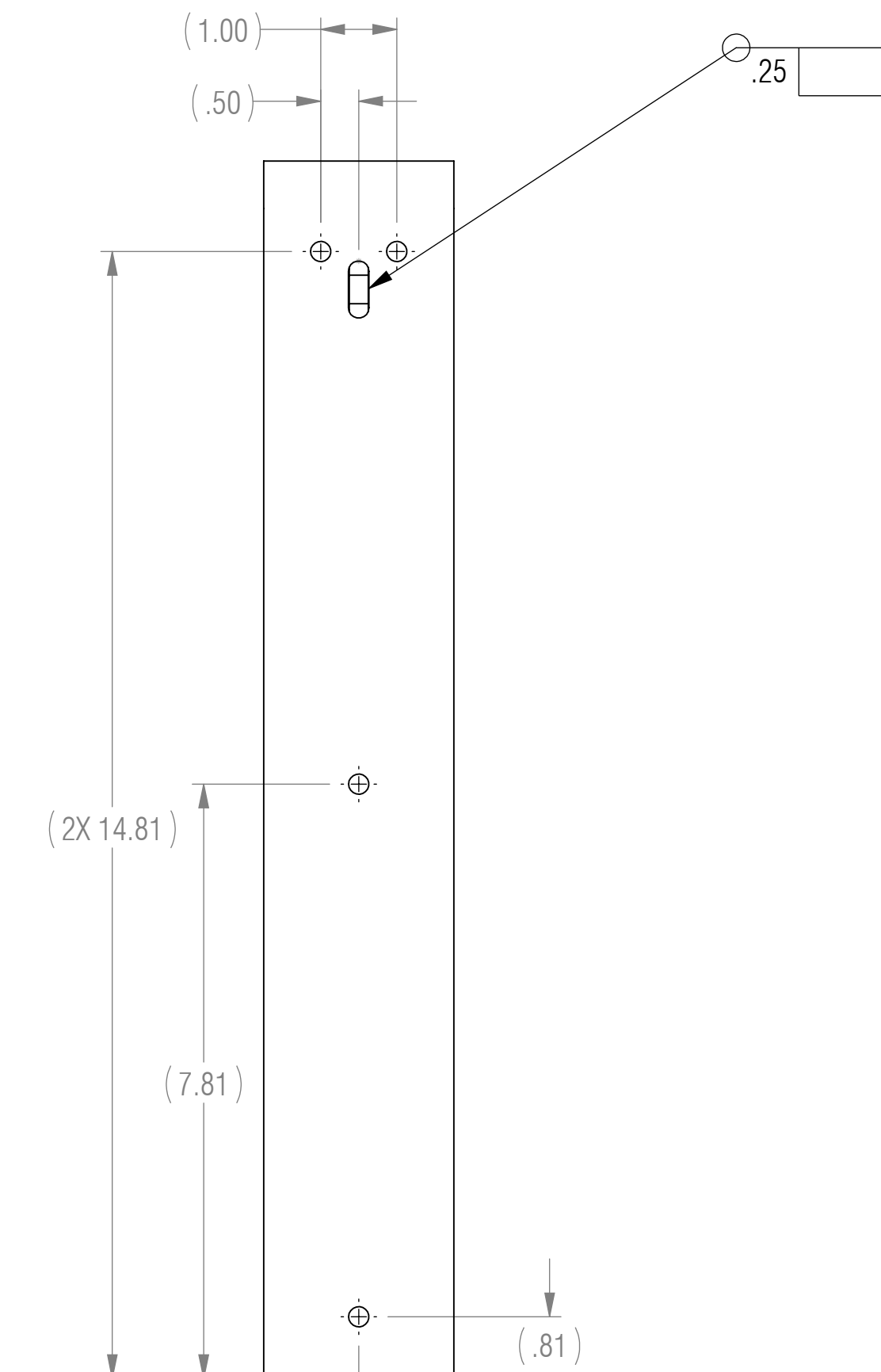
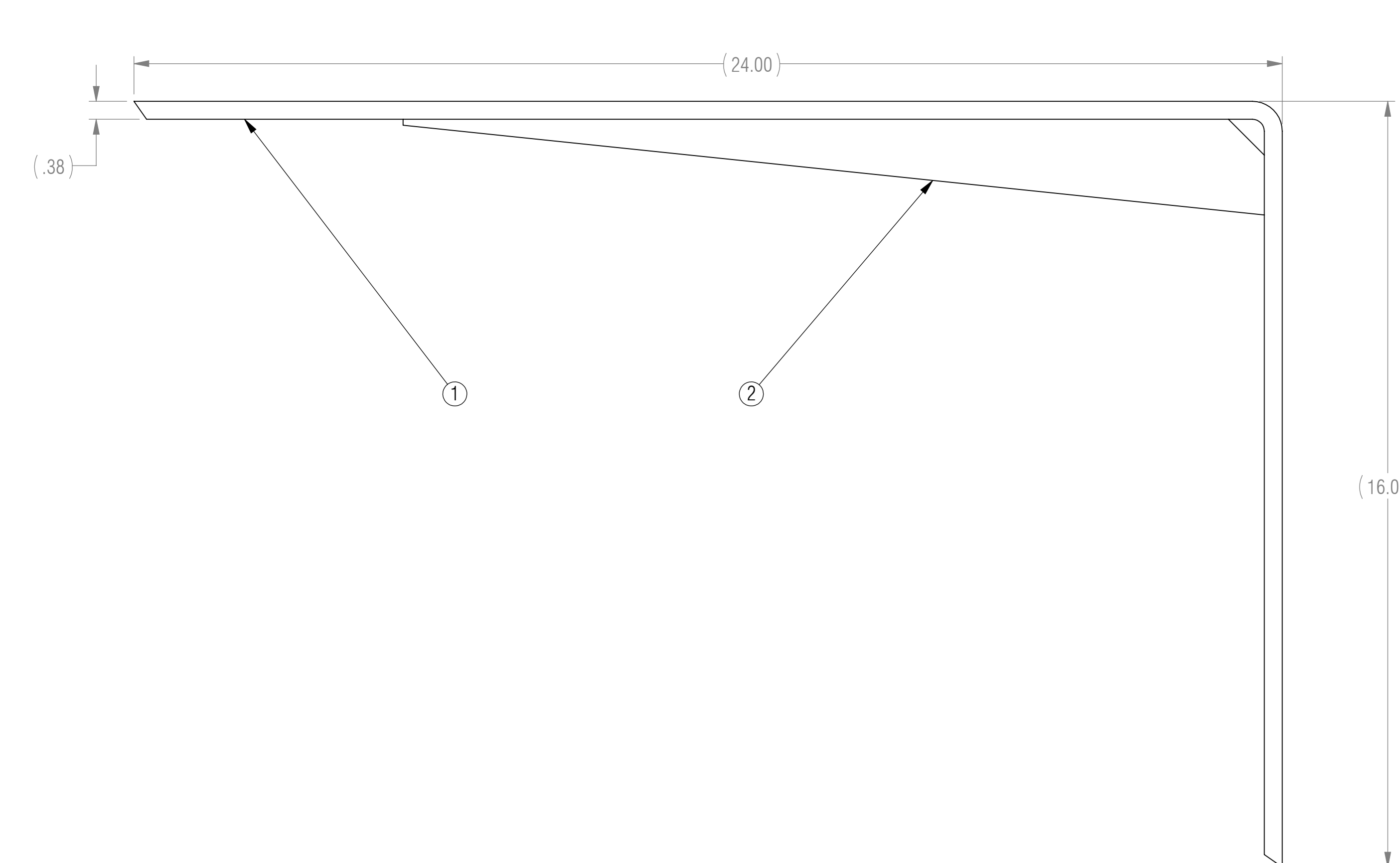

ISOMETRIC VIEW FOR REFERENCE ONLY

BOM TABLE			
ITEM NO.	PART NUMBER	DESCRIPTION	QTY.
1	FMM-24X16	FRONT MOUNTING MODIFIED	1
2	G-18	GUSSET	1

UNLESS OTHERWISE SPECIFIED: DIMENSIONS ARE IN INCHES		ENGINEER	
TOLERANCES ARE:		ENGINEER	
ANGLES		ENGINEER	
.XX ± .01	XX° ± 1°	CHECKED	CAS 12/10/2018
.XXX ± .005		DRAWN	KRH 12/10/2018
INTERPRET DRAWINGS IN ACCORDANCE WITH:		MANAGER APPROVAL	
ASME Y14.100	ENGINEERING DRAWING PRACTICES	THE INFORMATION ON THIS DRAWING IS PROPRIETARY AND SHALL NOT BE DISCLOSED, USED, OR DUPLICATED FOR PROCUREMENT OR MANUFACTURING PURPOSES WITHOUT THE EXPRESS WRITTEN CONSENT OF CENTERLINE STEEL, LLC	
ASME Y14.38	ABBREVIATIONS	THIRD ANGLE PROJECTION	
ASME Y14.5	DIMENSIONING AND TOLERANCING		
ASME Y14.6	SCREW THREAD REPRESENTATION	SIZE	D
ASME Y14.8	CASTINGS, FORGINGS & MOLDED PARTS	CAGE CODE	
AWS A2.4	WELDING SYMBOLS	DRAWING NO	FMP-24X16
IEEE STD 315	SYMBOLS FOR ELECTRICAL AND ELECTRONIC DIAGRAMS	REV	X1
USED ON APPLICATION		SCALE	1:2

Centerline Brackets

DRAWING TITLE: FRONT MOUNTING PLUS

SHEET 1 OF 1

RELEASED