

NOTES: UNLESS OTHERWISE SPECIFIED

- 1 MATERIAL: MATERIAL SPECIFIED AT INDIVIDUAL PART LEVEL
- 2 ALL DIMENSIONS ARE TO THEORETICAL SHARP.
- 3 REMOVE BURRS AND BREAK ALL SHARP EDGES .03 MAX.
- 4 ALL DIMENSIONS ARE IN INCHES UNLESS STATED OTHERWISE.
- 5 PARTS SHALL BE FREE OF GREASE AND CUTTING FLUID.
- 6 POWDER COAT PER MIL-PRF-24712A (TYPE 3, CLASS 3)

REVISIONS				
ZONE	REV.	DESCRIPTION	DATE	APPROVED
	X1	DEVELOPMENT	03/15/2017	KRH

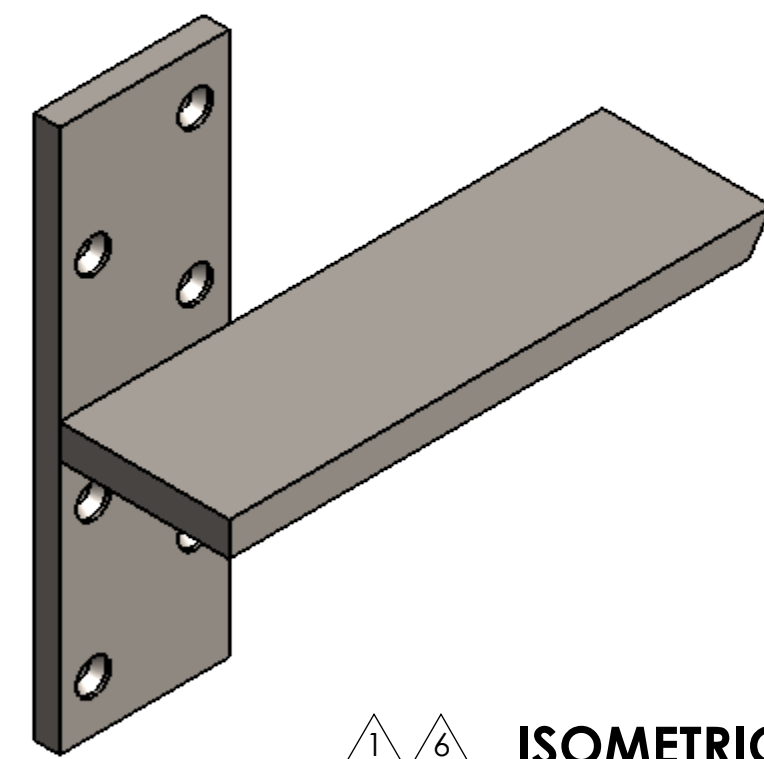
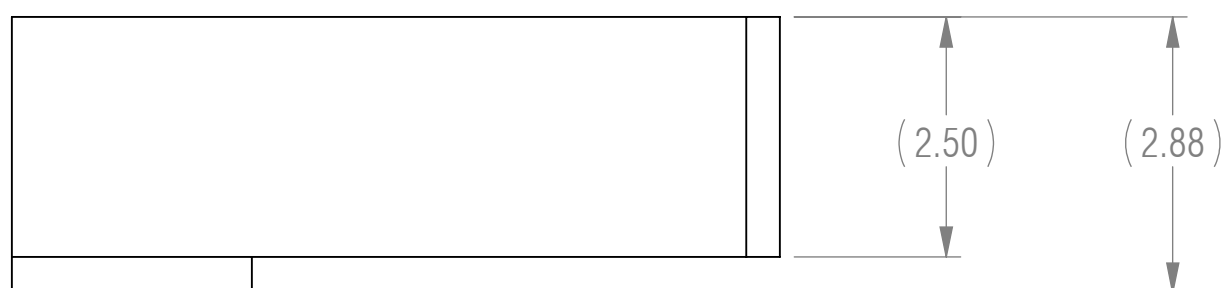
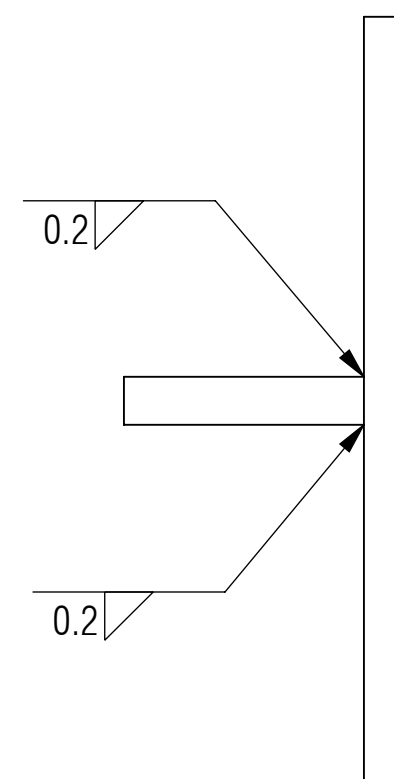
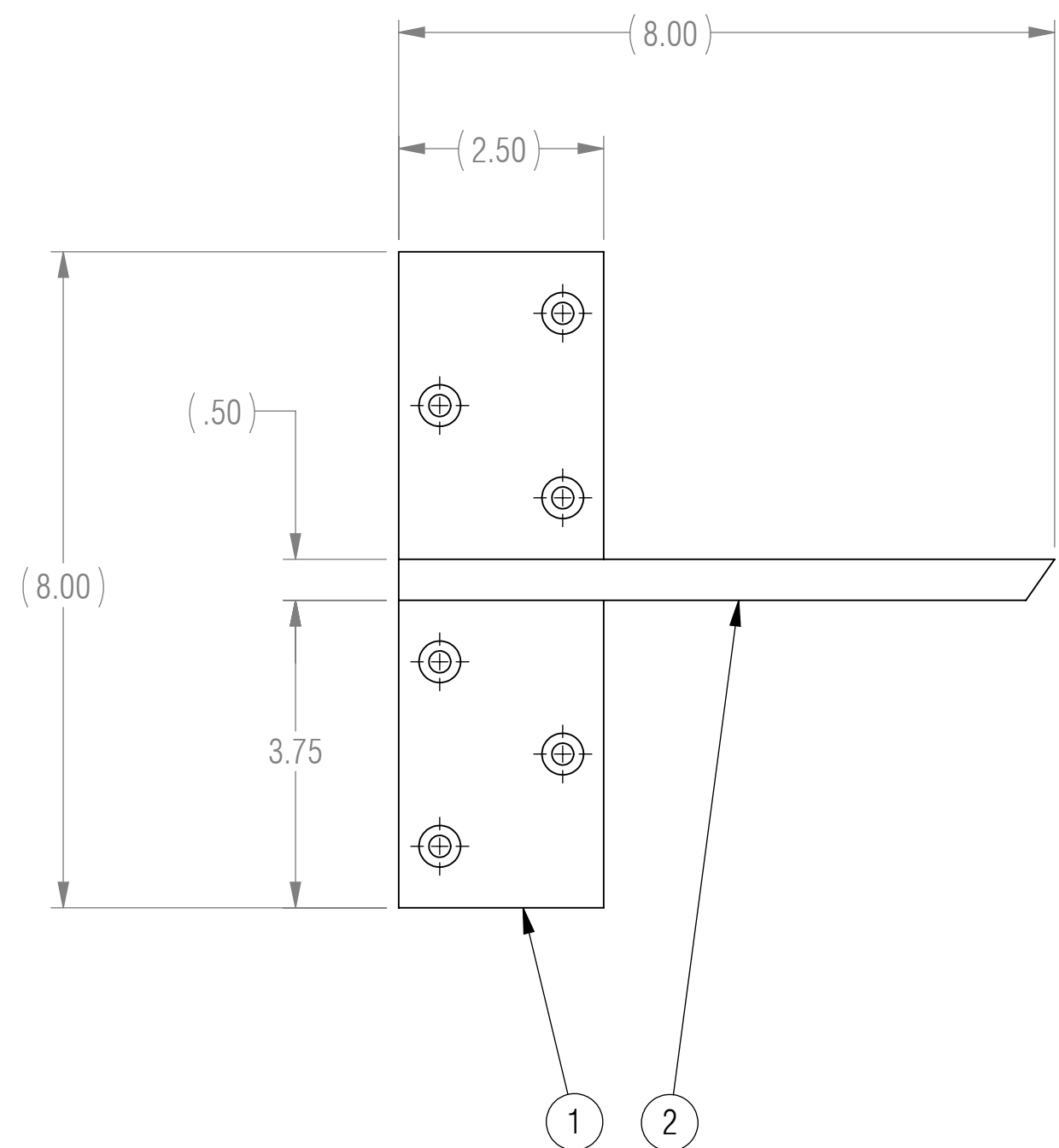

ISOMETRIC VIEW
FOR REFERENCE ONLY

BOM TABLE			
ITEM NO.	PART NUMBER	DESCRIPTION	QTY.
1	A-FWM	FWM FLANGE	1
2	HFWM-8.00	HORIZONTAL FLOATING WALL MOUNT	1

RELEASED

UNLESS OTHERWISE SPECIFIED: DIMENSIONS ARE IN INCHES		ENGINEER	
TOLERANCES ARE:		ENGINEER	
.XX ± .01	ANGLES	ENGINEER	
.XXX ± .005	XX° ± 1°	CHECKED	CAS 03/15/2017
		DRAWN	KRH 03/15/2017
INTERPRET DRAWINGS IN ACCORDANCE WITH:		MANAGER APPROVAL	
ASME Y14.100	ENGINEERING DRAWING PRACTICES	THE INFORMATION ON THIS DRAWING IS PROPRIETARY AND SHALL NOT BE DISCLOSED, USED, OR DUPLICATED FOR PROCUREMENT OR MANUFACTURING PURPOSES WITHOUT THE EXPRESS WRITTEN CONSENT OF CENTERLINE STEEL, LLC	
ASME Y14.38	ABBREVIATIONS	THIRD ANGLE PROJECTION	
ASME Y14.5	DIMENSIONING AND TOLERANCING		
ASME Y14.6	SCREW THREAD REPRESENTATION		
ASME Y14.8	CASTINGS, FORGINGS & MOLDED PARTS	USED ON APPLICATION	
AWS A2.4	WELDING SYMBOLS		
IEEE STD 315	SYMBOLS FOR ELECTRICAL AND ELECTRONIC DIAGRAMS		

DRAWING TITLE
FLOATING WALL MOUNT BRACKET

SIZE D	CAGE CODE	DRAWING NO FWM-R08	REV X1
SCALE 1:2		SHEET 1 OF 1	