

NOTES: UNLESS OTHERWISE SPECIFIED

- 1 MATERIAL: MATERIAL SPECIFIED AT INDIVIDUAL PART LEVEL
- 2 ALL DIMENSIONS ARE TO THEORETICAL SHARP.
- 3 REMOVE BURRS AND BREAK ALL SHARP EDGES .03 MAX.
- 4 ALL DIMENSIONS ARE IN INCHES UNLESS STATED OTHERWISE.
- 5 PARTS SHALL BE FREE OF GREASE AND CUTTING FLUID.
- 6 POWDER COAT PER MIL-PRF-24712A (TYPE 3, CLASS 3)

REVISIONS				
ZONE	REV.	DESCRIPTION	DATE	APPROVED
	X1	DEVELOPMENT	03/15/2017	KRH

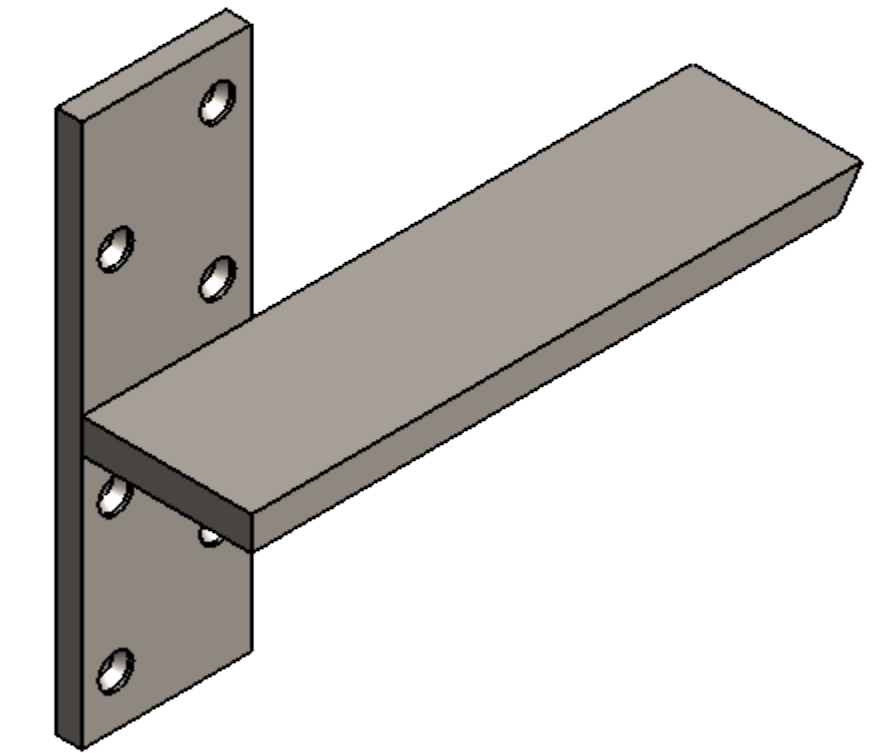
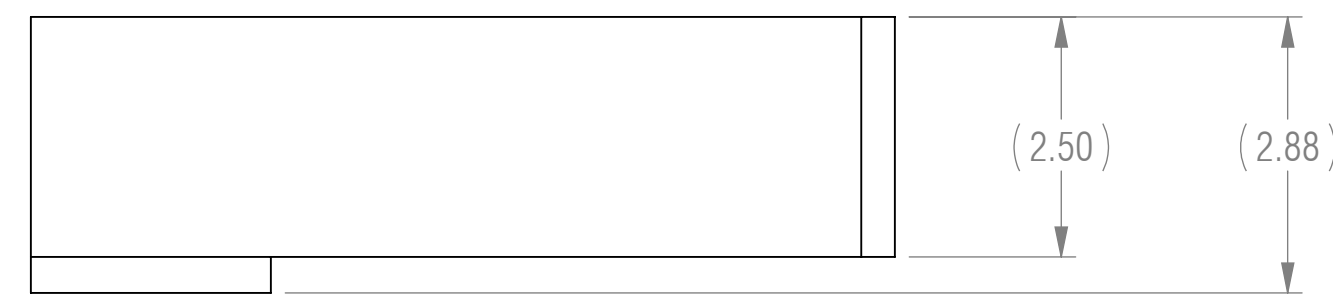
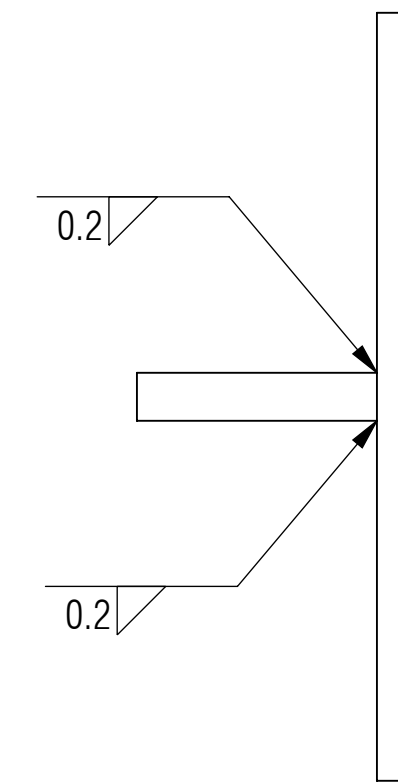
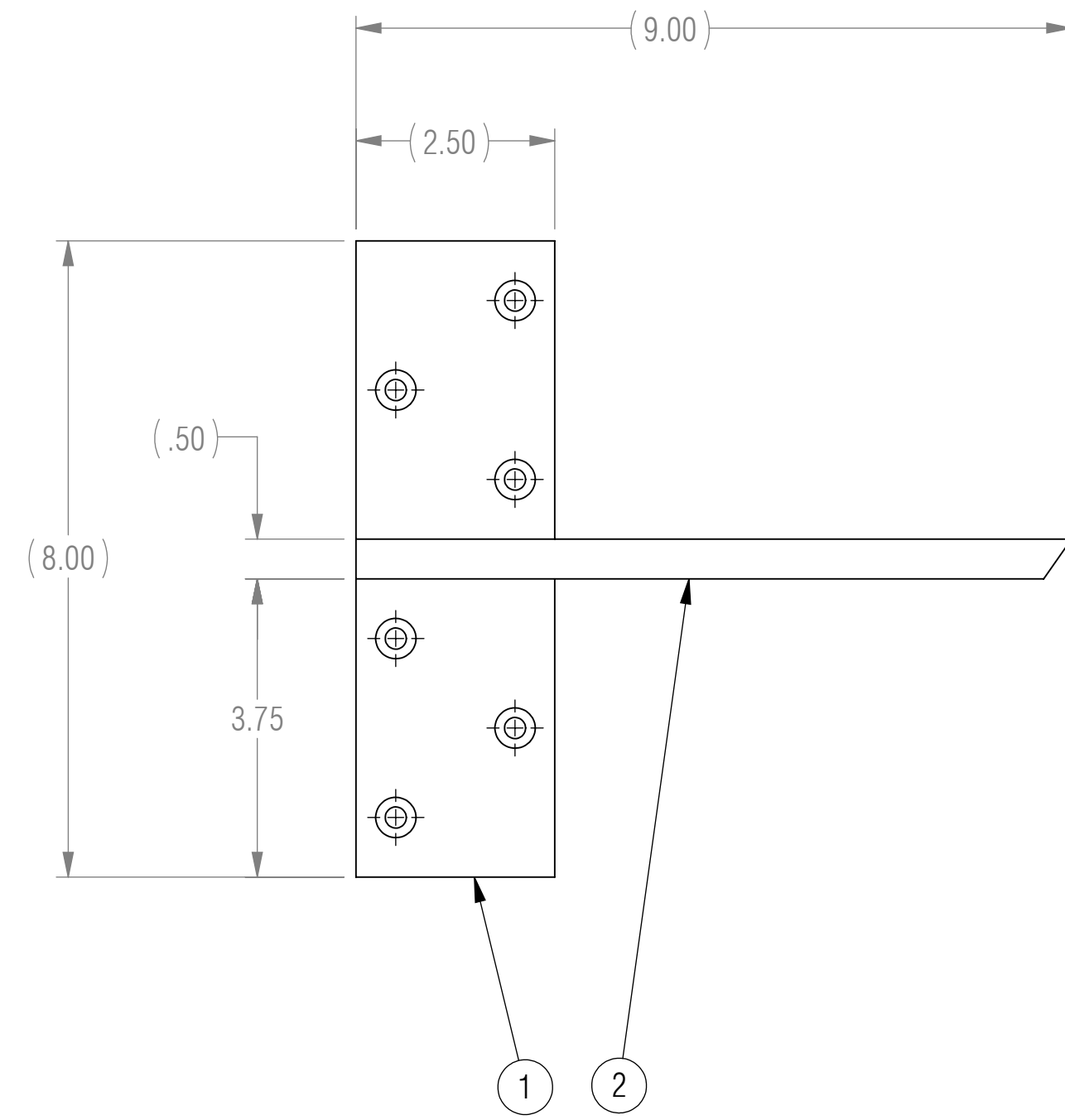

**ISOMETRIC VIEW**  
FOR REFERENCE ONLY

BOM TABLE			
ITEM NO.	PART NUMBER	DESCRIPTION	QTY.
1	A-FWM	FWM FLANGE	1
2	HFWM-9.00	HORIZONTAL FLOATING WALL MOUNT	1

UNLESS OTHERWISE SPECIFIED: DIMENSIONS ARE IN INCHES		ENGINEER		
TOLERANCES ARE:		ENGINEER		
.XX ± .01	ANGLES XX° ± 1°	ENGINEER		
.XXX ± .005		CHECKED CAS	03/15/2017	
		DRAWN KRH	03/15/2017	
INTERPRET DRAWINGS IN ACCORDANCE WITH:		MANAGER APPROVAL		
ASME Y14.100 ENGINEERING DRAWING PRACTICES	THE INFORMATION ON THIS DRAWING IS PROPRIETARY AND SHALL NOT BE DISCLOSED, USED, OR DUPLICATED FOR PROCUREMENT OR MANUFACTURING PURPOSES WITHOUT THE EXPRESS WRITTEN CONSENT OF CENTERLINE STEEL, LLC			
ASME Y14.38 ABBREVIATIONS	THIRD ANGLE PROJECTION			
ASME Y14.5 DIMENSIONING AND TOLERANCING				
ASME Y14.6 SCREW THREAD REPRESENTATION				SIZE D
ASME Y14.8 CASTINGS, FORGINGS & MOLDED PARTS	SCALE 1:2	SHEET 1 OF 1		
AWS A2.4 WELDING SYMBOLS				
IEEE STD 315 SYMBOLS FOR ELECTRICAL AND ELECTRONIC DIAGRAMS				

RELEASED