

NOTES: UNLESS OTHERWISE SPECIFIED

- 1. MATERIAL: MATERIAL SPECIFIED AT INDIVIDUAL PART LEVEL
- 2. ALL DIMENSIONS ARE TO THEORETICAL SHARP.
- 3. REMOVE BURRS AND BREAK ALL SHARP EDGES .03 MAX.
- 4. ALL DIMENSIONS ARE IN INCHES UNLESS STATED OTHERWISE.
- 5. PARTS SHALL BE FREE OF GREASE AND CUTTING FLUID.
- 6. POWDER COAT PER MIL-PRF-24712A (TYPE 3, CLASS 3)

REVISIONS				
ZONE	REV.	DESCRIPTION	DATE	APPROVED
	X1	DEVELOPMENT	03/21/2017	KRH

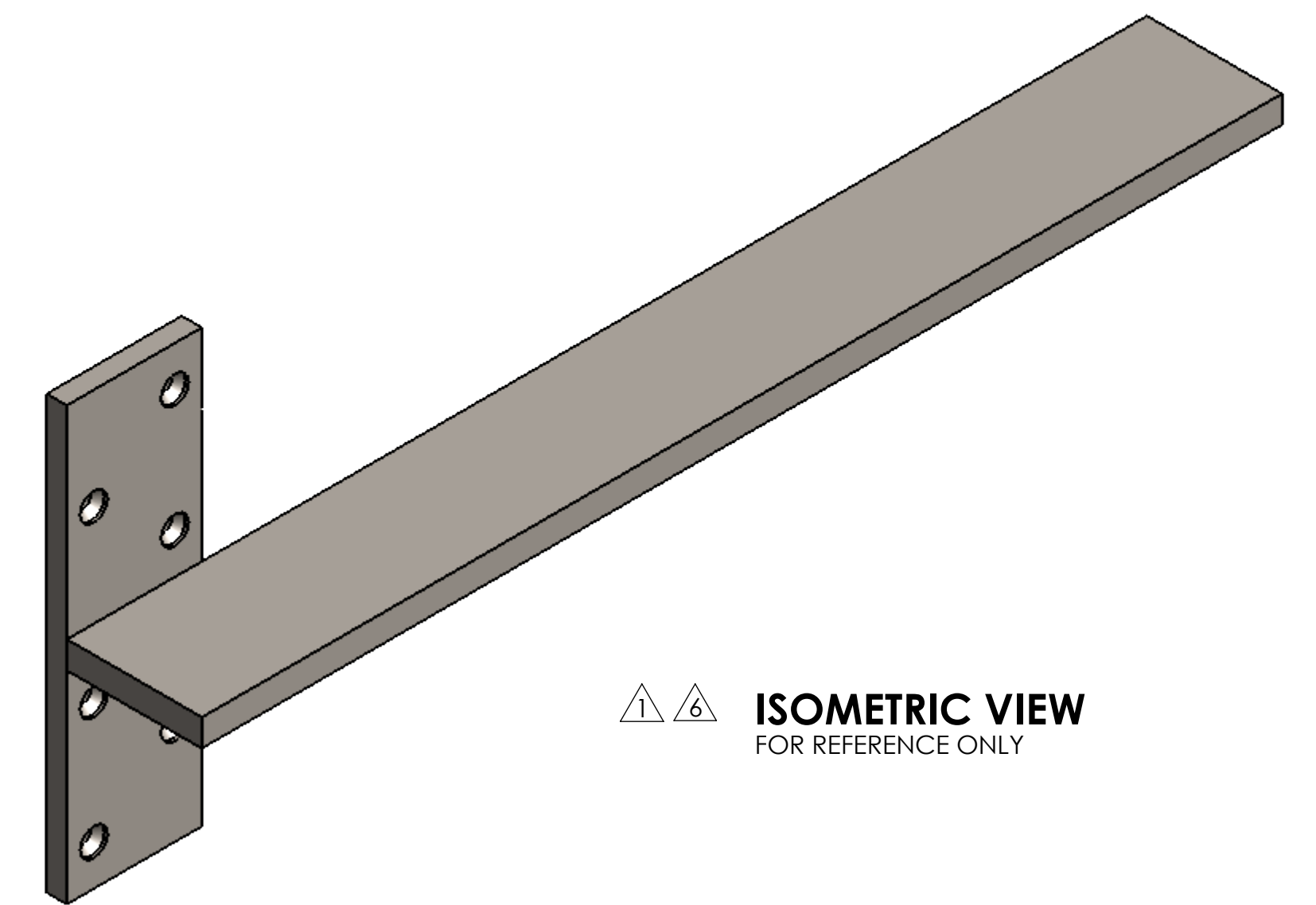
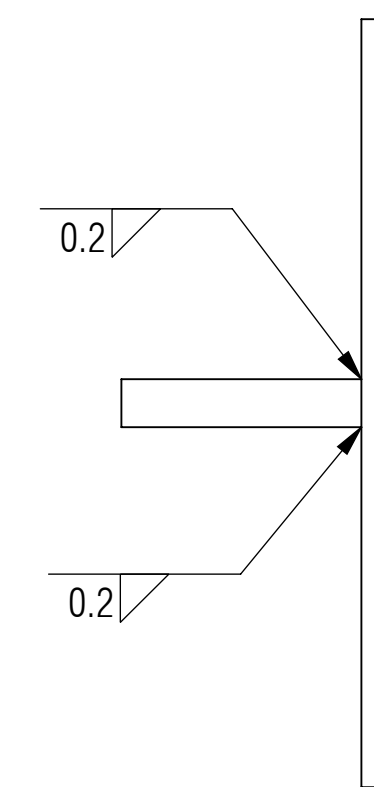
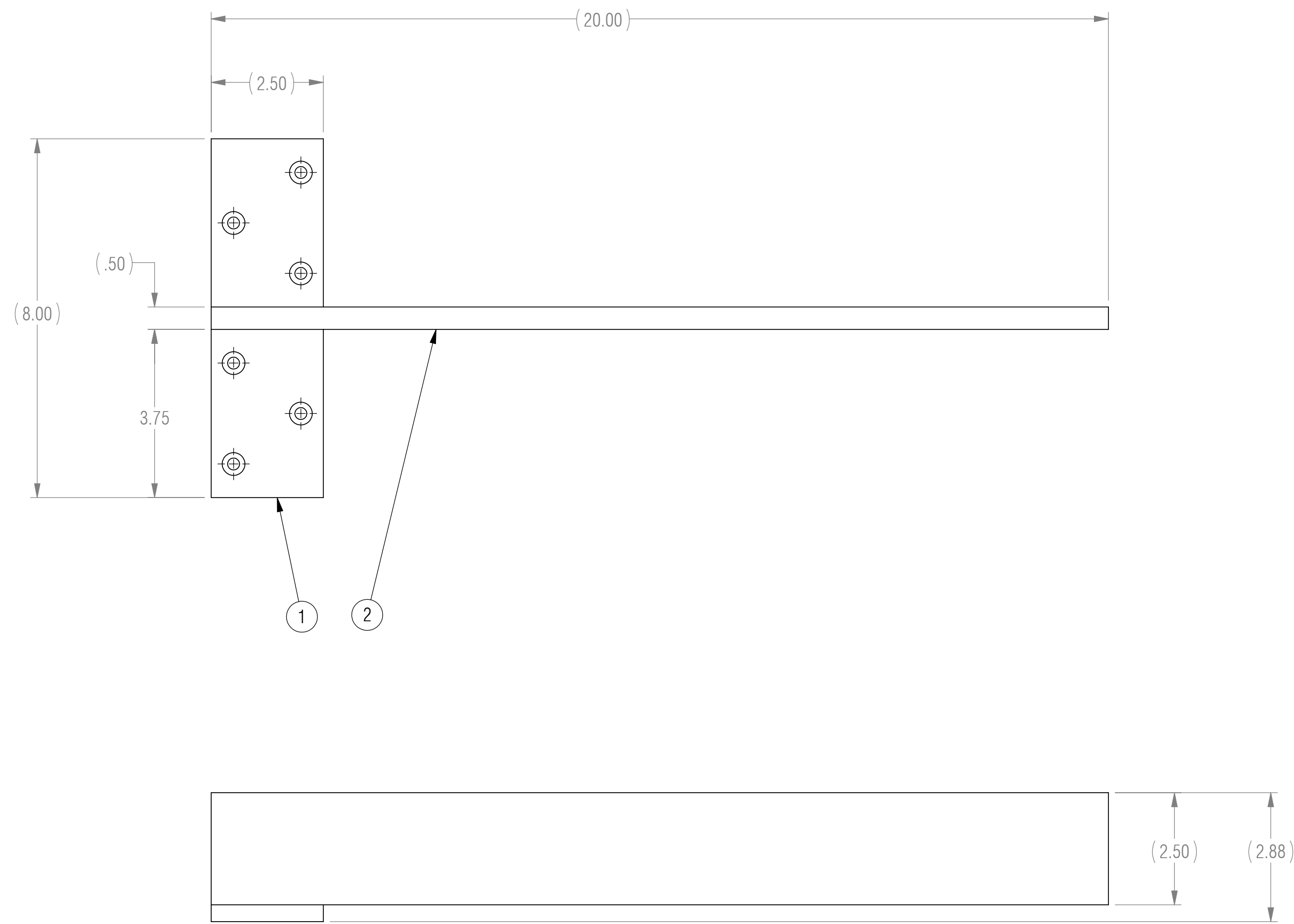

**ISOMETRIC VIEW**  
FOR REFERENCE ONLY

BOM TABLE			
ITEM NO.	PART NUMBER	DESCRIPTION	QTY.
1	A-FWM	FWM FLANGE	1
2	H00H-20.00	HORIZONTAL SUPPORT, 0 ANGLE, 0 HOLES, VARIABLE LENGTH	1

RELEASED

UNLESS OTHERWISE SPECIFIED: DIMENSIONS ARE IN INCHES		ENGINEER		
TOLERANCES ARE:		ENGINEER		
ANGLES		ENGINEER		
.XX ± .01	XX° ± 1°	CHECKED	CAS 03/21/2017	
.XXX ± .005		DRAWN	KRH 03/21/2017	
INTERPRET DRAWINGS IN ACCORDANCE WITH:		MANAGER APPROVAL		THE INFORMATION ON THIS DRAWING IS PROPRIETARY AND SHALL NOT BE DISCLOSED, USED, OR DUPLICATED FOR PROCUREMENT OR MANUFACTURING PURPOSES WITHOUT THE EXPRESS WRITTEN CONSENT OF CENTERLINE STEEL, LLC
ASME Y14.100 ENGINEERING DRAWING PRACTICES		THIRD ANGLE PROJECTION 		
ASME Y14.38 ABBREVIATIONS				
ASME Y14.5 DIMENSIONING AND TOLERANCING				
ASME Y14.6 SCREW THREAD REPRESENTATION		SCALE 1:2		DRAWING NO <b>FWM-U20</b>
ASME Y14.8 CASTINGS, FORGINGS & MOLDED PARTS		CAGE CODE		
AWS A2.4 WELDING SYMBOLS		DRAWING NO		REV
IEEE STD 315 SYMBOLS FOR ELECTRICAL AND ELECTRONIC DIAGRAMS		SHEET 1 OF 1		X1