

| REVISION STATUS - ALL SHEETS ARE THE SAME REVISION | | | | |
|--|------|-------------|------------|----------|
| ZONE | REV. | DESCRIPTION | DATE | APPROVED |
| | X1 | DEVELOPMENT | 01/31/2017 | KRH |

NOTES: UNLESS OTHERWISE SPECIFIED

- 1 MATERIAL: ASTM A36, HOT ROLLED STEEL, OR CENTERLINE STEEL, LLC APPROVED EQUIVALENT.
- 2 ALL DIMENSIONS ARE TO THEORETICAL SHARP.
- 3 REMOVE BURRS AND BREAK ALL SHARP EDGES .03 MAX.
- 4 ALL DIMENSIONS ARE IN INCHES UNLESS STATED OTHERWISE.
- 5 PARTS SHALL BE FREE OF GREASE AND CUTTING FLUID.
- 6 POWDER COAT PER MIL-PRF-24712A (TYPE 3, CLASS 3)

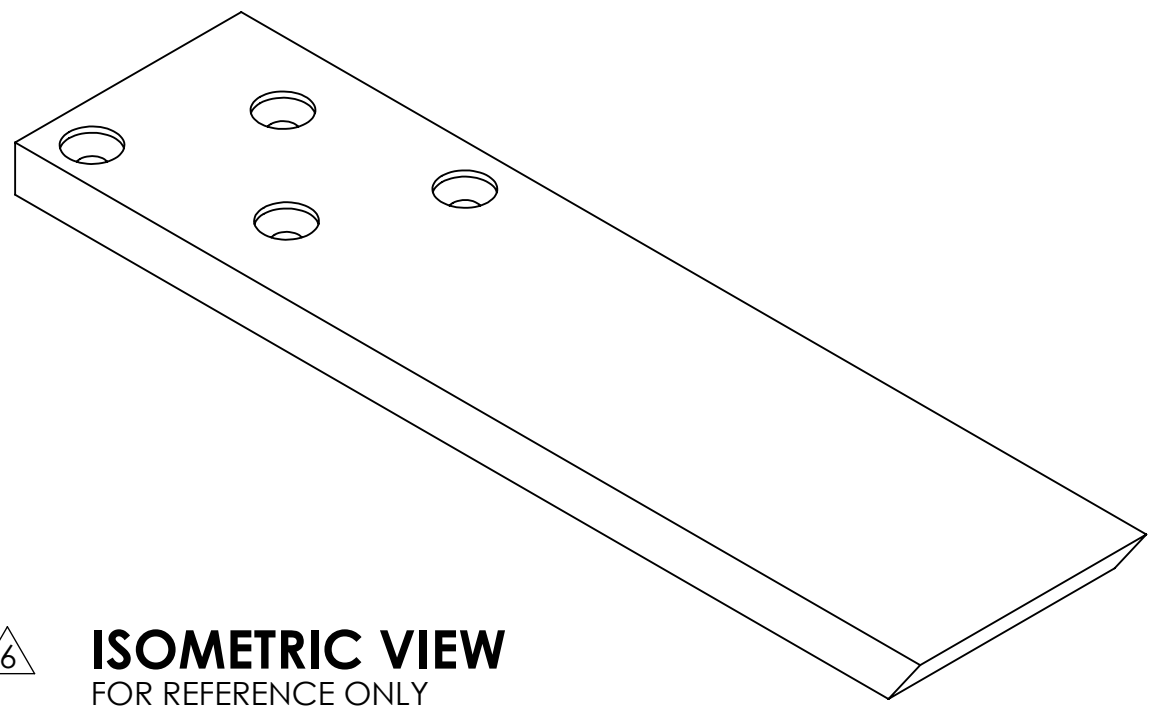

ISOMETRIC VIEW FOR REFERENCE ONLY

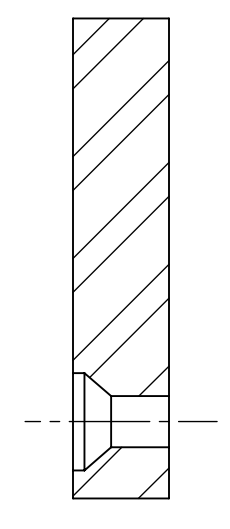
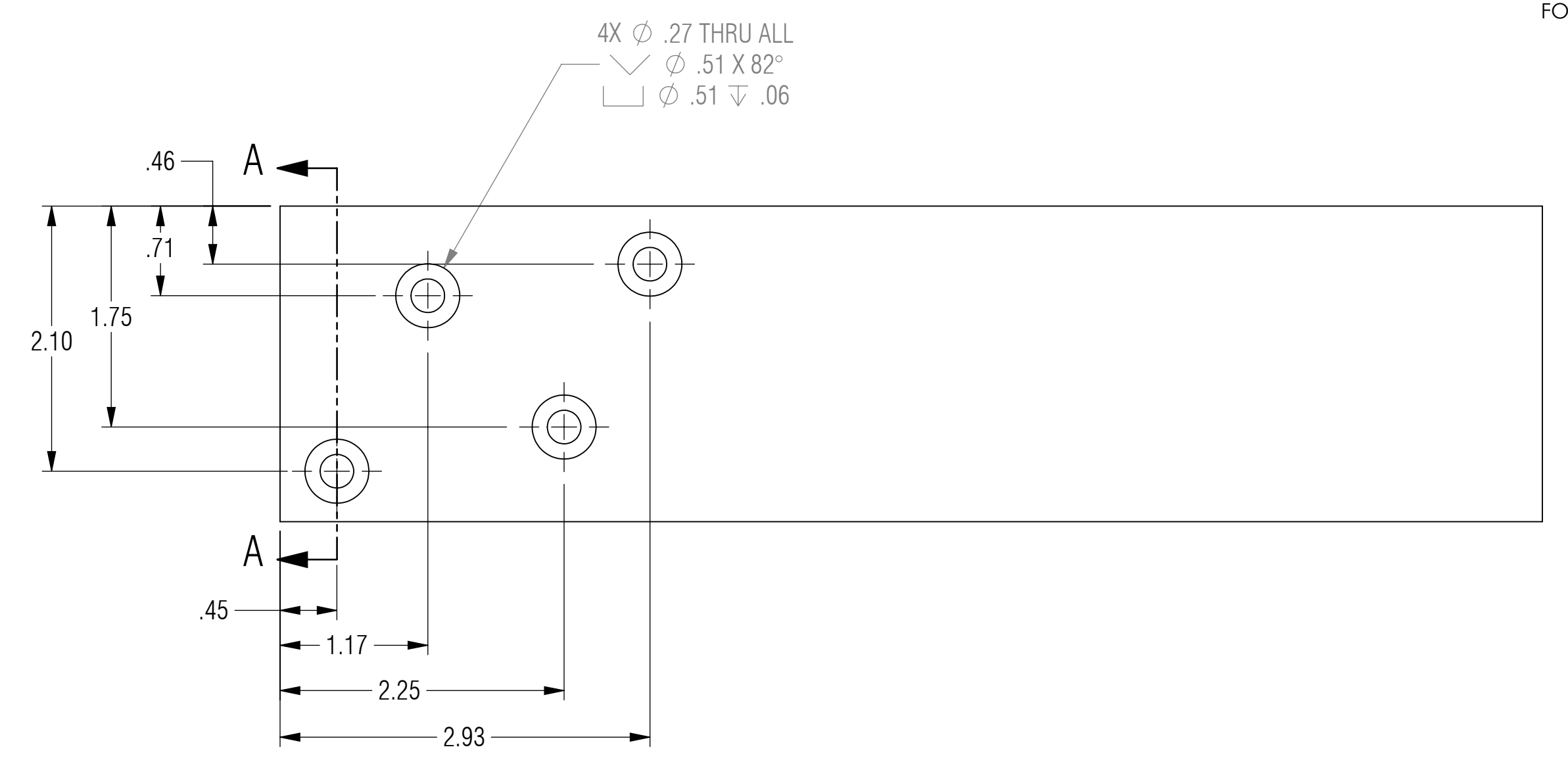

SECTION A-A

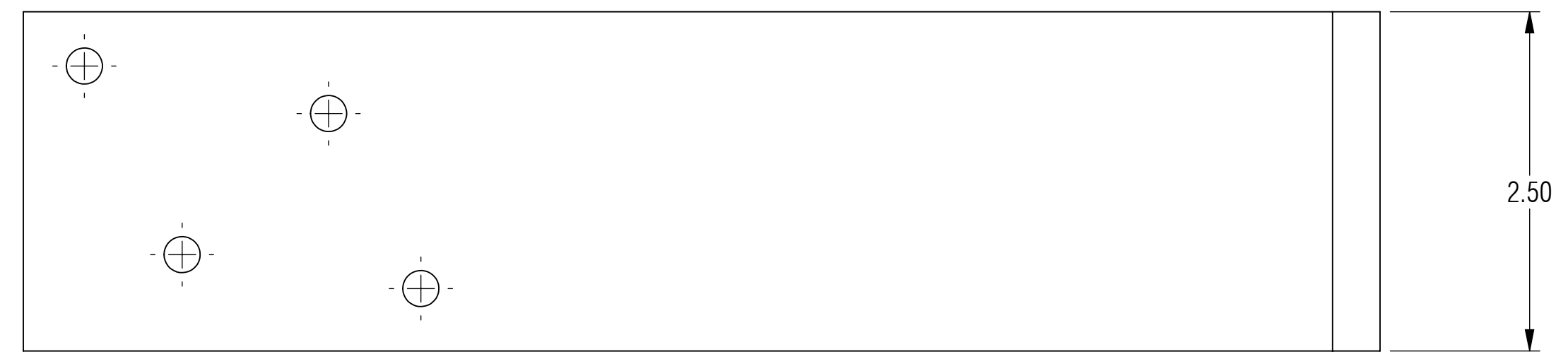
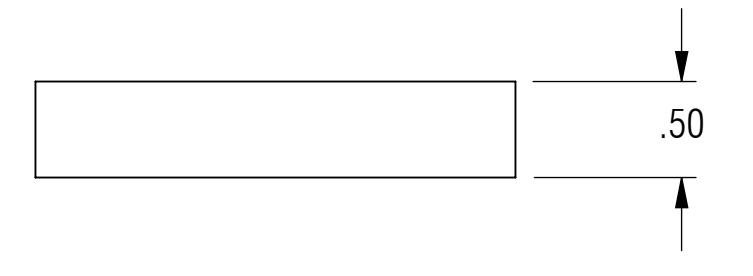
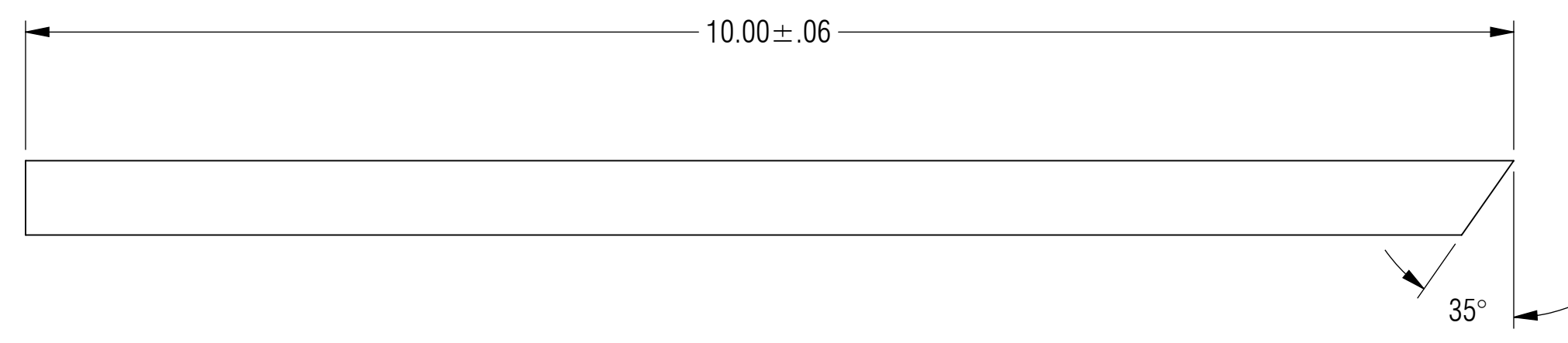

RELEASED

| | | | | |
|---|--|---|----------------|--------------------|
| UNLESS OTHERWISE SPECIFIED: DIMENSIONS ARE IN INCHES | | ENGINEER | | |
| TOLERANCES ARE: | | ENGINEER | | |
| .XX ± .01 | ANGLES XX° ± 1° | CHECKED | CAS 01/31/2017 | |
| .XXX ± .005 | | DRAWN | KRH 01/31/2017 | |
| INTERPRET DRAWINGS IN ACCORDANCE WITH: | | MANAGER APPROVAL | | DRAWING TITLE |
| ASME Y14.100 ENGINEERING DRAWING PRACTICES | ASME Y14.38 ABBREVIATIONS | THE INFORMATION ON THIS DRAWING IS PROPRIETARY AND SHALL NOT BE DISCLOSED, USED, OR DUPLICATED FOR PROCUREMENT OR MANUFACTURING PURPOSES WITHOUT THE EXPRESS WRITTEN CONSENT OF CENTERLINE STEEL, LLC | | STANDARD BRACKET |
| ASME Y14.5 DIMENSIONING AND TOLERANCING | ASME Y14.6 SCREW THREAD REPRESENTATION | THIRD ANGLE PROJECTION | | SIZE D |
| ASME Y14.8 CASTINGS, FORGINGS & MOLDED PARTS | AWS A2.4 WELDING SYMBOLS | | | CAGE CODE |
| IEEE STD 315 SYMBOLS FOR ELECTRICAL AND ELECTRONIC DIAGRAMS | | | | DRAWING NO SB4H-10 |
| USED ON APPLICATION | | | | REV X1 |
| | | | | SCALE 1:1 |
| | | | | SHEET 1 OF 1 |