

CURTAIN PLAN

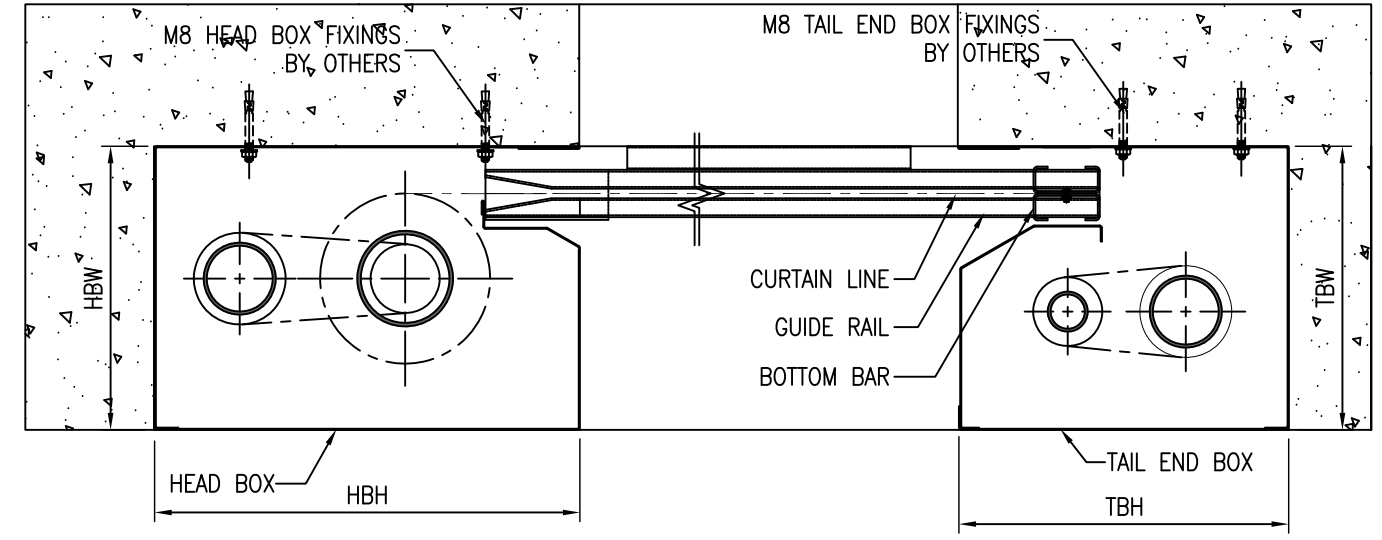

ENLARGED VIEW - A

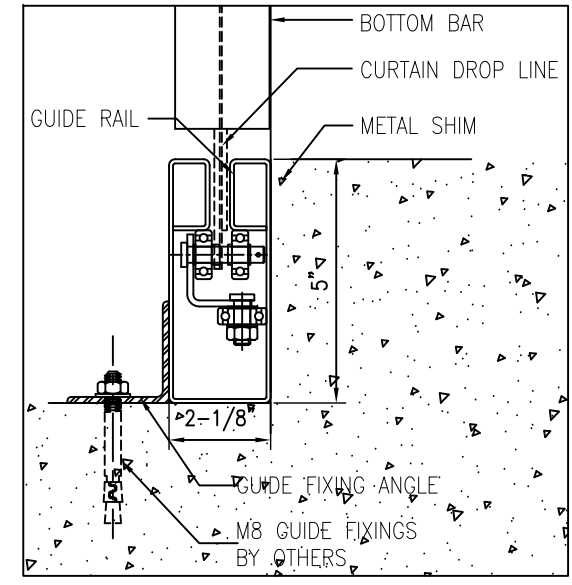

ENLARGED VIEW - B

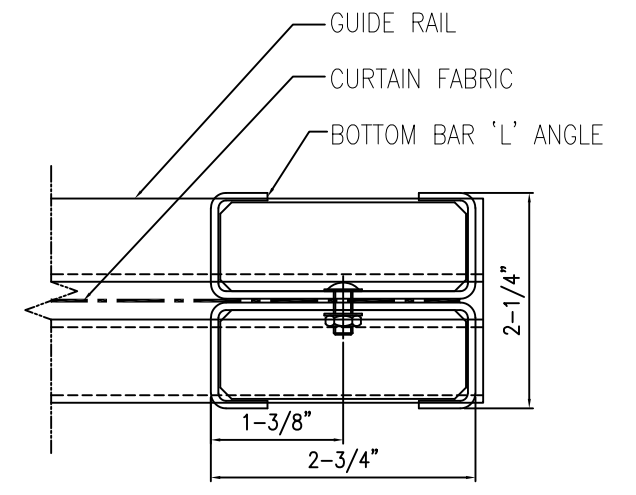

ENLARGED DETAIL - BOTTOM BAR

FIRE CURTAIN SPECIFICATION:

CURTAIN FABRIC	MANUFACTURED FROM STAINLESS STEEL, WIRE REINFORCED, WOVEN GLASS FIBRE, FABRIC COATED ON EACH SIDE WITH SILVER POLYURETHANE VWG 690
GUIDE RAIL	2 mm THK GALVANIZED STEEL GUIDE RAIL
BOTTOM BAR	2mm THK GALVANIZED STEEL BOTTOM BAR
CURTAIN BOX	1.2mmTHK GALVANISED STEEL
END PLATE	3mmTHK GALVANISED STEEL END PLATES AND BRACKETS
MOTOR	INTERNAL, ELECTRIC, TUBULER GEARED CONSTANT SPEED MOTOR
POWER SUPPLY	SINGLE PHASE, 230V,13A,50Hz

