

		REVISION HISTORY		
REV	DESCRIPTION	ECN #	MFG APPROVED BY	DATE
2	CORRECT DIM. .538 WAS .500	N/A	KEVIN P.	9/13/18
2	REMOVED I.D. MARKS	N/A	KEITH T.	9/14/15

NOTE:
 1. DIMENSIONS AND NOTES ON THIS DRAWING SUPERSEDE TITLE BLOCK
 2. ALUMINUM ASSOCIATION STANDARD TOLERANCES APPLY FOR EXTRUSION PROFILE.
 3. ALL DIMENSIONAL LIMITS APPLY BEFORE COATING, I.E. PAINT COAT OR ANODIZE COAT.

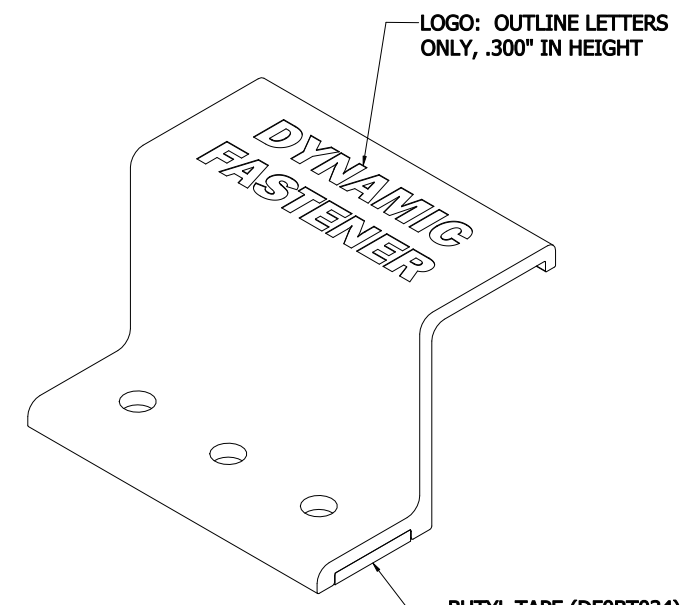
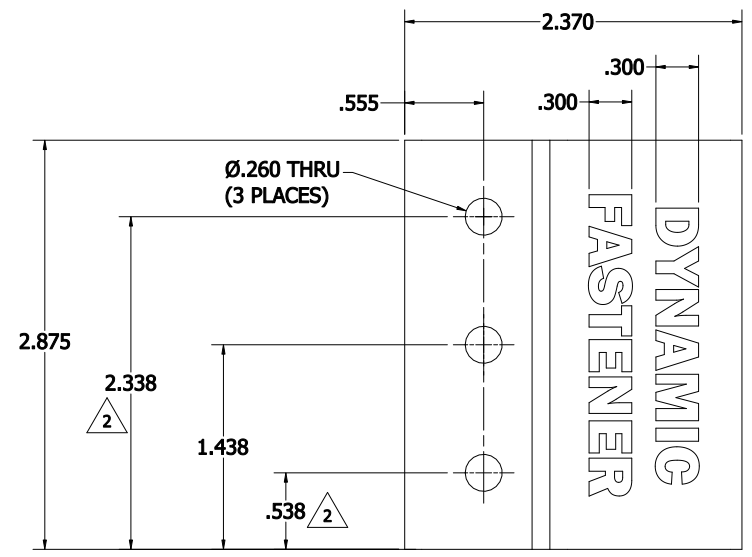

ISOMETRIC VIEW

BUTYL TAPE (DF0BT034)
 WILL BE INSTALLED AT
 FAB PACKING DEPT.

ITEM CODE: 5244F9003

DRAWING APPROVED BY: _____

DATE: _____

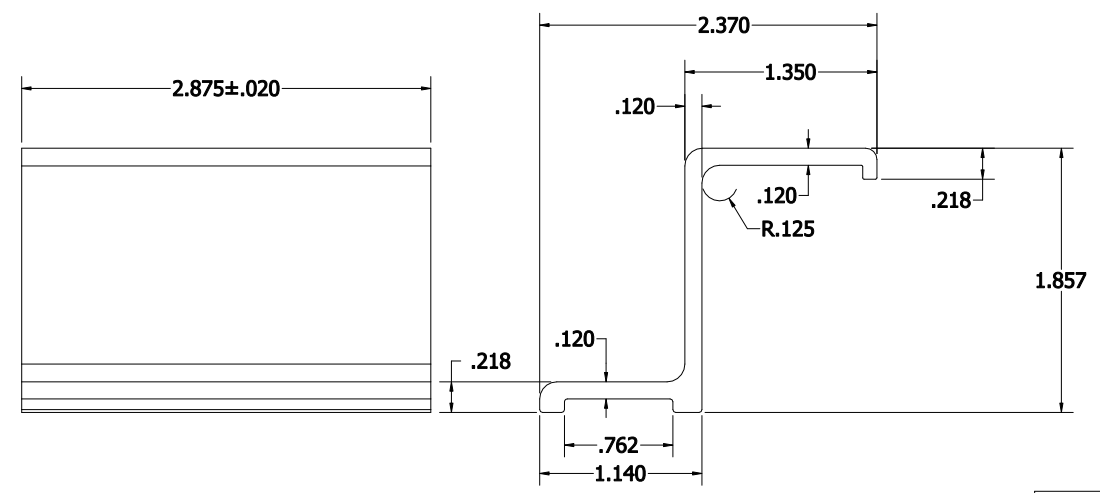

EXT. VIEW, DIE AF-5244
 SEE DIE PRINT

DIMENSIONS ARE IN INCHES.
 ALUMINUM ASSOCIATION STANDARD
 TOLERANCES APPLY FOR EXTRUSION
 PROFILE ONLY. UNLESS OTHERWISE
 SPECIFIED, FAB DIMS TOLERANCES ARE:
 FRACTIONAL: ±.01; ANGULARITY: ±1'
 [.XXX : ±.020] [.XX : ±.031] [.X : ±.063]
 DRAWING GENERATED BY INVENTOR SOFTWARE

THE INFORMATION CONTAINED IN THIS DRAWING IS THE SOLE PROPERTY
 OF DYNAMIC FASTENER. ANY REPRODUCTION IN PART OR WHOLE
 WITHOUT THE WRITTEN PERMISSION OF DYNAMIC FASTENER. IS PROHIBITED.

DRAWN BY: DHLE		DATE: 10/15/2018		DYNAMIC FASTENER	
FINISH: MILL FINISH		MATERIAL: EXT DIE AF-5244			
MASS: N/A		ITEM CODE: 5244F9003		CUSTOMER: DYNAMIC FASTENER	
LENGTH: 2.875"		CAD FILE: M/FAB/ALEX/SAP DOC/DYNAMIC FASTENER		PART NAME: DYNA-MOUNT 1	
SIZE: C	DRAWING NO.: DYNA-MOUNT 1		REV. 2		
DO NOT SCALE DRAWING			SHEET 1 OF 1		