

NOTE:
 1. DIMENSIONS AND NOTES ON THIS DRAWING SUPERSEDE TITLE BLOCK
 2. ALUMINUM ASSOCIATION STANDARD TOLERANCES APPLY FOR EXTRUSION PROFILE.
 3. ALL DIMENSIONAL LIMITS APPLY BEFORE COATING, I.E. PAINT COAT OR ANODIZE COAT.

REVISION HISTORY				
REV	DESCRIPTION	ECN #	MFG APPRO	DATE
0				

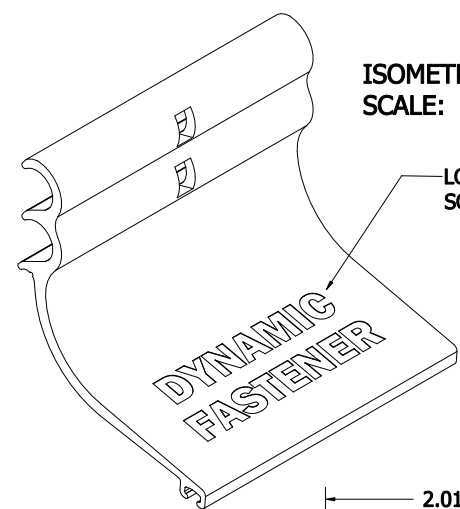

ISOMETRIC VIEW
 SCALE: 1.25X

LOGO: .300" IN HEIGHT
 SOLID LETTER, NOT OUTLINE

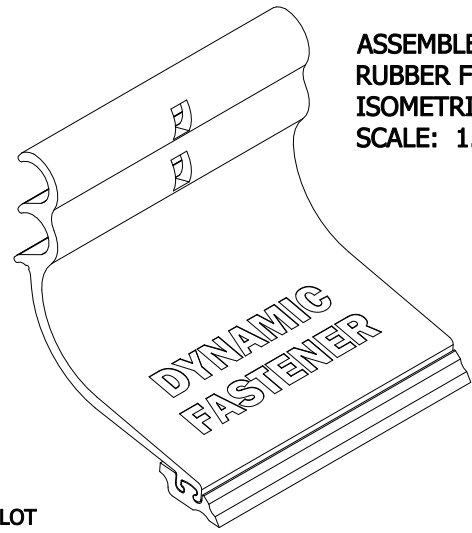

ASSEMBLED WITH RUBBER FOOT
ISOMETRIC VIEW
 SCALE: 1.25X

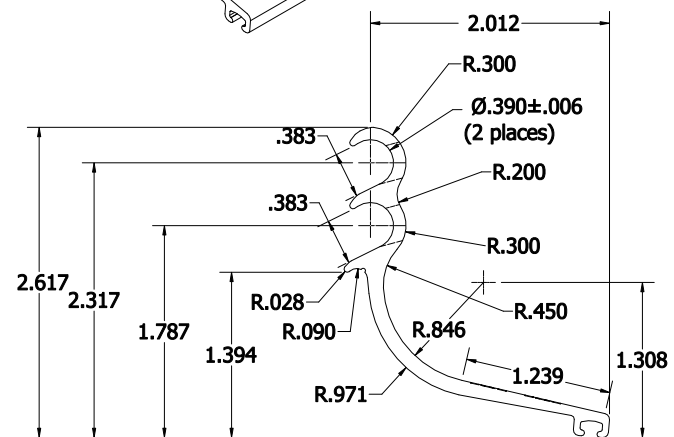

EXTRUSION VIEW
 SEE DIE PRINT

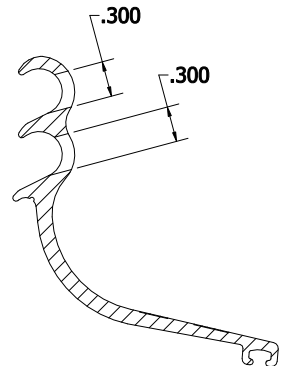
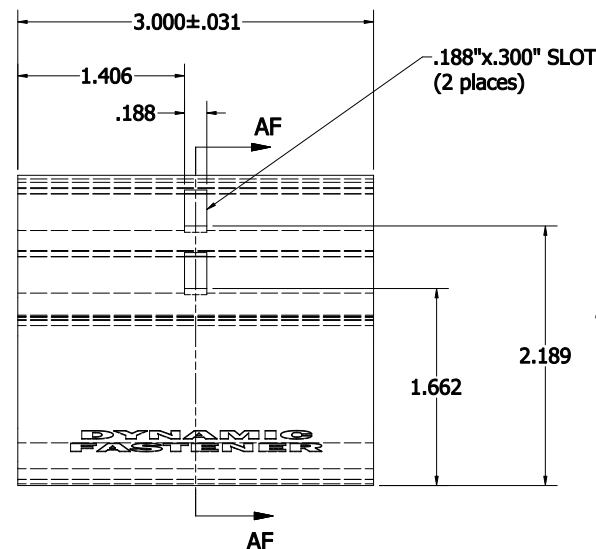

SECTION VIEW AF-AF
 SCALE 1.25

DRAWING APPROVED BY:

DATE:

THE INFORMATION CONTAINED IN THIS DRAWING IS THE SOLE PROPERTY OF AFCO INDUSTRIES, INC. ANY REPRODUCTION IN PART OR WHOLE WITHOUT THE WRITTEN PERMISSION OF AFCO INDUSTRIES, INC. IS PROHIBITED.

DIMENSIONS ARE IN INCHES.
 ALUMINUM ASSOCIATION STANDARD TOLERANCES APPLY FOR EXTRUSION PROFILE ONLY, UNLESS OTHERWISE SPECIFIED, FAB DIMS TOLERANCES ARE:
 FRACTIONAL: ±.01" ; ANGULARITY: ±1'
 [.XXX : ±.020] [.XX : ±.031] [.X : ±.063]
 DRAWING GENERATED BY INVENTOR SOFTWARE

DRAWN BY: DUC LE	DATE: 5/10/2019	AFCO INDUSTRIES, Inc.		REV. 0
FINISH: MILL	MASS: N/A	3400 ROY ST., ALEXANDRIA LA 71302 * Ph: 800.551.6576		
MATERIAL: ALUM ALLOY 6005A-T61	ITEM CODE: 5679F9003	CUSTOMER: DYNAMIC FASTENER		SHEET 1 OF 1
LENGTH: 3.00"	CAD FILE: M:/FAB/ALEX/SAP DOC/DYNAMIC FASTENER/	PART NAME: RETRO SNO-DAM 2		
DO NOT SCALE DRAWING		SIZE: C	DRAWING NO.: RETRO SNODAM 2	