

PARTS LIST & FINISH SELECTION				
ITEM	DESCRIPTION	MATERIAL	QTY	WEIGHT / lbs
1	CEILING	ANEGADA, BRUSHED ALUMINUM T-FRAME CEILING WITH CLEAR LAQUER 1.5 x 1.5 x .125" WITH 6 -STAINLESS #4 FINISH DROP-IN PANELS & 6 SOLOBEAM LED LIGHT FIXTURES	1	94.235
2	UPPER PANELS	1/2" FRB FACED WITH WILSONART WILD CHERRY #7054-60 STANDARD FINISH AND BLACK PVC EDGE BANDING	1 (SET)	167.717
3	RAIL BACKER PANELS	1/2" FRB FACED WITH #4 STAINLESS SATIN FINISH AND BLACK PVC EDGE BANDING	3	42.565
4	BOTTOM PANELS	1/2" FRB FACED WITH WILSONART WILD CHERRY #7054-60 STANDARD FINISH CROSS GRAIN AND BLACK PVC EDGE BANDING	3	66.508
5	BACK HANDRAIL	1.5" ROUND #4 STAINLESS WITH STANDARD STAND OFF BRACKETS	1	15.119
6	SIDE HANDRAILS	1.5" ROUND #4 STAINLESS WITH STANDARD STAND OFF BRACKETS ONE AT EACH SIDE WALL	2	17.384
7	RECESSED REVEALS	STAINLESS #4 FINISH	1 (SET)	23.011

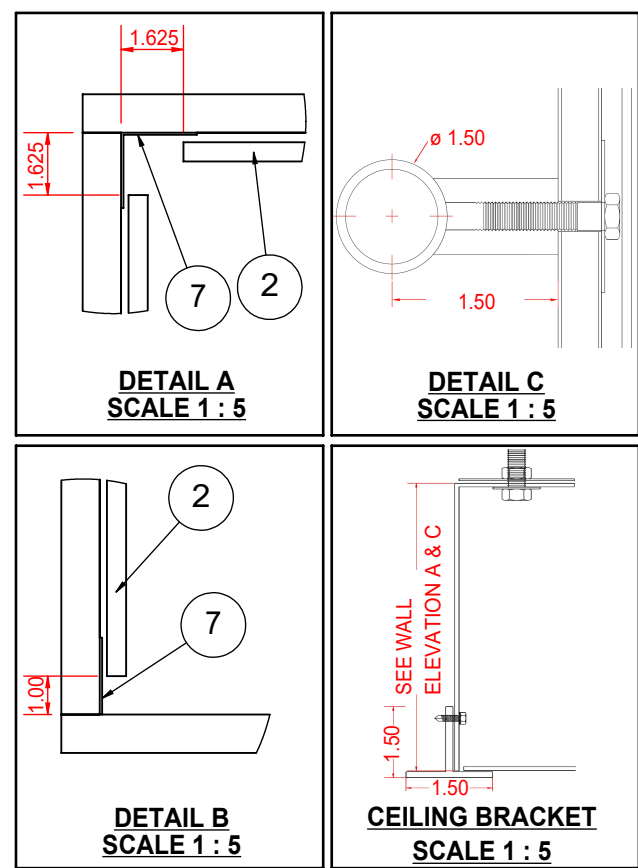
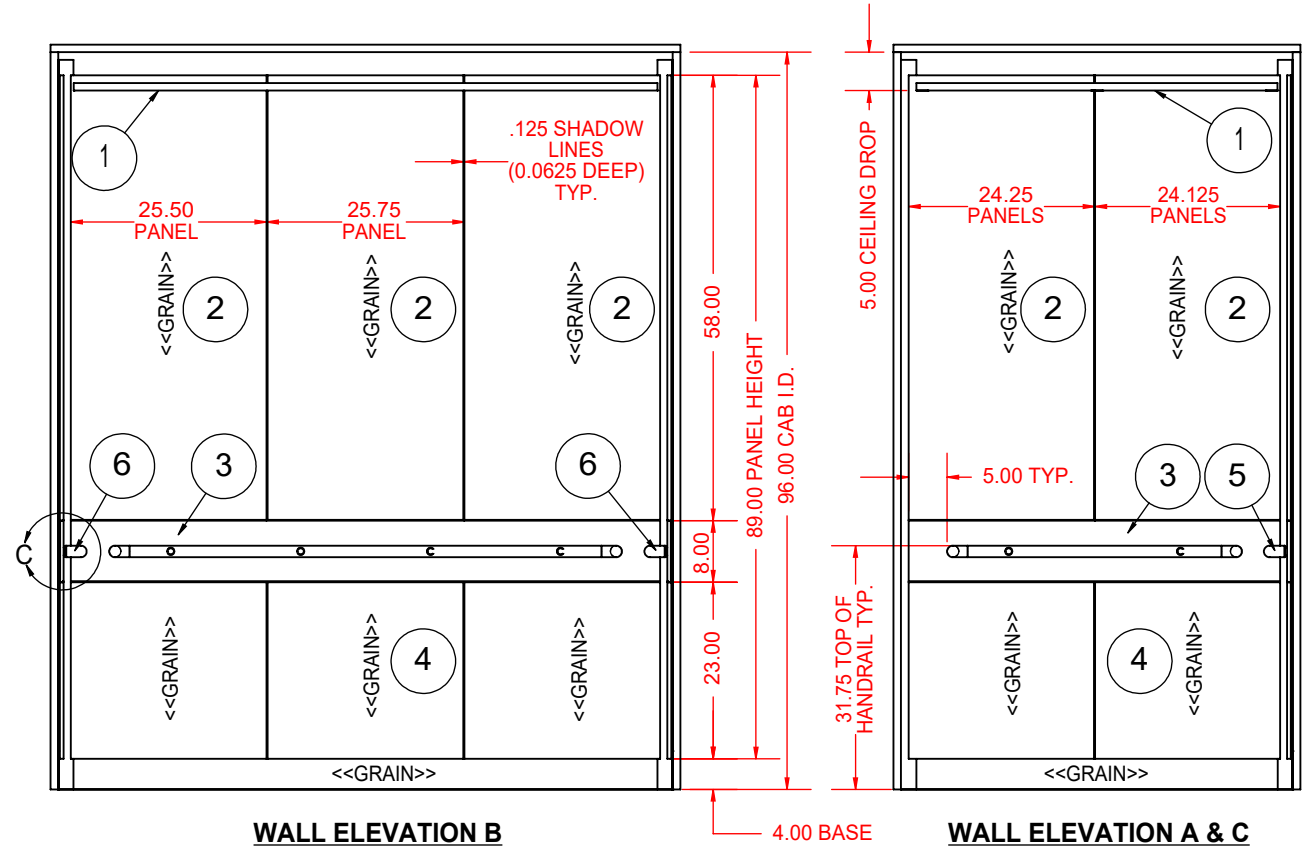

8896 West State Rd. 236
 Middletown, IN 47356
 T: 800.800.4960

F.A.C. JOB NUMBER: XXXXX	CAPACITY: 2500 lbs	JOB NAME: JOB NAME HERE
CAB I.D.: CAB XX		CONTACT: YOUR NAME HERE!
WALL PANELS: KINGSTON		CEILING TYPE: ANEGADA T-FRAME
SALES REP: SALES REP NAME HERE	DATE: XX/XX/20XX	DRAWING SCALE: 1 : 25
REVISIONS:	FABRICATION APPROVAL SIGNATURE:	

SPECIFIC PRODUCT NOTES		UNIT CONVERSION	
ALL DIMENSIONS ARE GIVEN IN INCHES			
1/16 = 0.0625	9/16 = 0.5625	1/2 = 0.5000	
1/8 = 0.1250	5/8 = 0.6250		
3/16 = 0.1875	11/16 = 0.6875		
1/4 = 0.2500	3/4 = 0.7500		
5/16 = 0.3125	13/16 = 0.8125		
3/8 = 0.3750	7/8 = 0.8750		
7/16 = 0.4375	15/16 = 0.9375		