

FOLD DOWN LADDER FRAME TYPICALLY MOUNTS INTO SUSPENSION KIT (SOLD SEPARATELY). THE SUSPENSION KIT MOUNTS TO THE ROOF STRUCTURE ABOVE AND HOLDS THE FOLD DOWN LADDER FRAME IN PLACE. VARIOUS SUSPENSION KITS AVAILABLE TO ACCOMMODATE VARYING CEILING HEIGHT

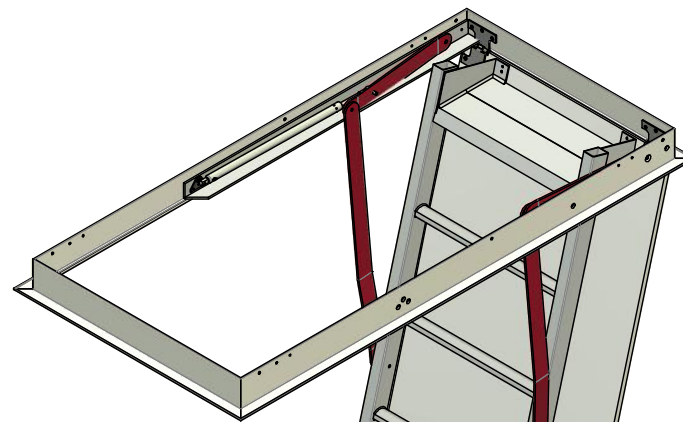

PROJECT REF: \_\_\_\_\_  
 CONTRACTOR: \_\_\_\_\_  
 APPROVED BY: \_\_\_\_\_  
 SIGN HERE: \_\_\_\_\_

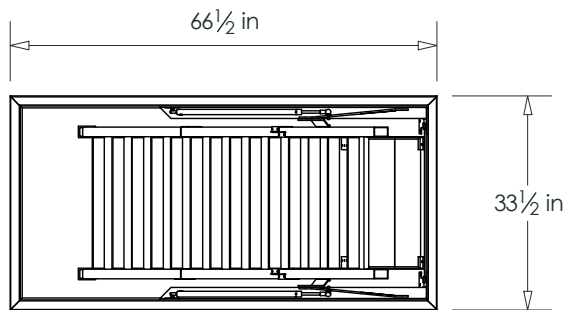
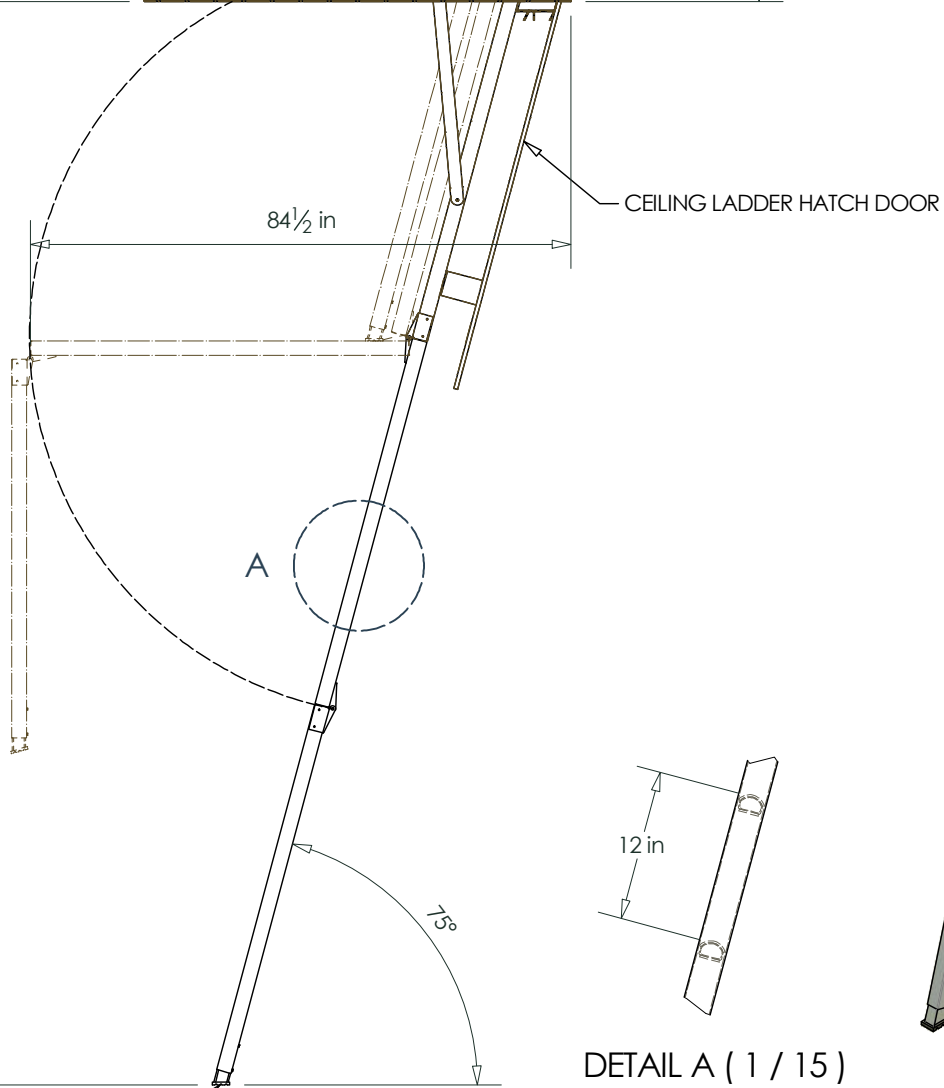
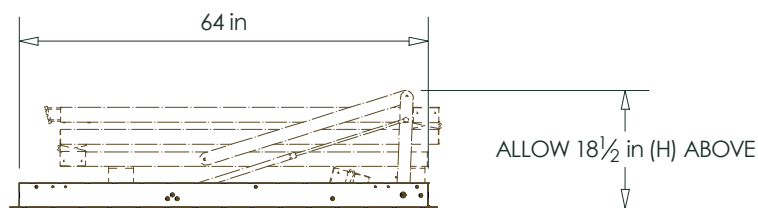
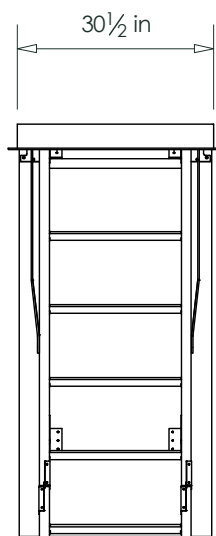

ALUMINUM EXTRUDED STILE  
 GRADE 6106-T6  
 2-1/4" X 1-1/2" X 1/8"

1-1/4" SQ. SERRATED RUNG  
 (TYP) ALUMINUM 6106-T6.  
 WELDED TO STILES

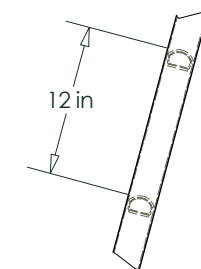
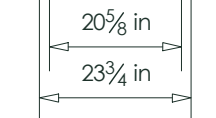

DETAIL A ( 1 / 15 )

LADDER SUPPLIED IN KIT FORM. THE LADDER BASE IS DESIGNED TO BE CUT TO REQUIRED HEIGHT ON SITE

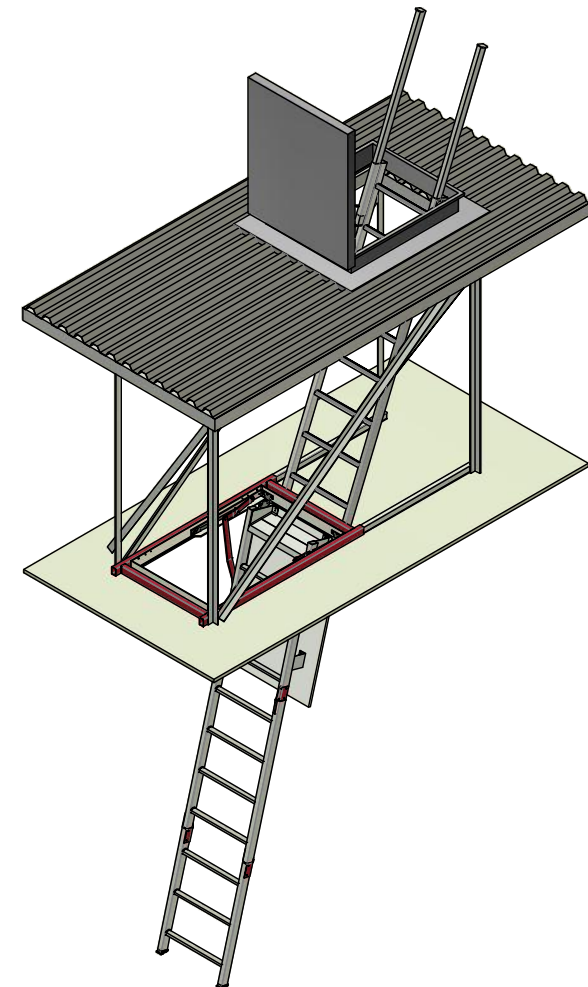

REV	DATE	BY	APP	COMMENTS
2	2/05/2019	SW	RP	NOTES ADDED
1	23/11/2018	SW	RP	RE-DRAWN IN INVENTOR

DRN:	DATE:
SW	23/11/2018
CHK:	DATE:
RP	3/04/2019
APP:	DATE:
RP	3/04/2019

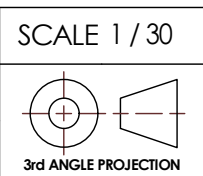

DIMENSION TOLERANCES UNLESS NOTED OTHERWISE	
X	± 1mm
X.X	± 0.25mm
X.XX	± 0.1mm
ANGLE	± 1°

**FIXFASTUSA**  
 3921 PERRY BOULEVARD  
 WHITESTOWN IN 46075 USA  
 T +1 317 769 7710  
 F +1 317 769 5560  
 E sales@fixfastusa.com  
 W www.fixfastusa.com

Maximum safety. Minimum fuss.  
 THIS DRAWING REMAINS THE PROPERTY OF FIXFAST USA® AND MAY NOT BE CHANGED WITHOUT WRITTEN PERMISSION

DESCRIPTION	KATTClimb MAXI FOLD DOWN LADDER		SHT #	1/1
MATERIAL	FINISH		SIZE	B
DWG No.	RL63	FAB No.	REV	2