

PARTS LIST		
ITEM	PART NUMBER	DESCRIPTION
1	GW384	KATTSAFE HANDRAIL BRACE
2	GW379	KATTSAFE KNEERAIL END CAP
3	GW378	KATTSAFE HANDRAIL END CAP
4	GW374.CTL	KATTSAFE HANDRAIL
5	GW375.CTL	KATTSAFE KNEERAIL
6	GW382	KATTSAFE HANDRAIL ELBOW - ADJUSTABLE
7	GW383	KATTSAFE KNEERAIL ELBOW - ADJUSTABLE
8	GW351TUSA	KATTSAFE TOP MOUNT GUARDRAIL POST
9	GW300T	KATTSAFE FREESTANDING WEIGHTED BASE

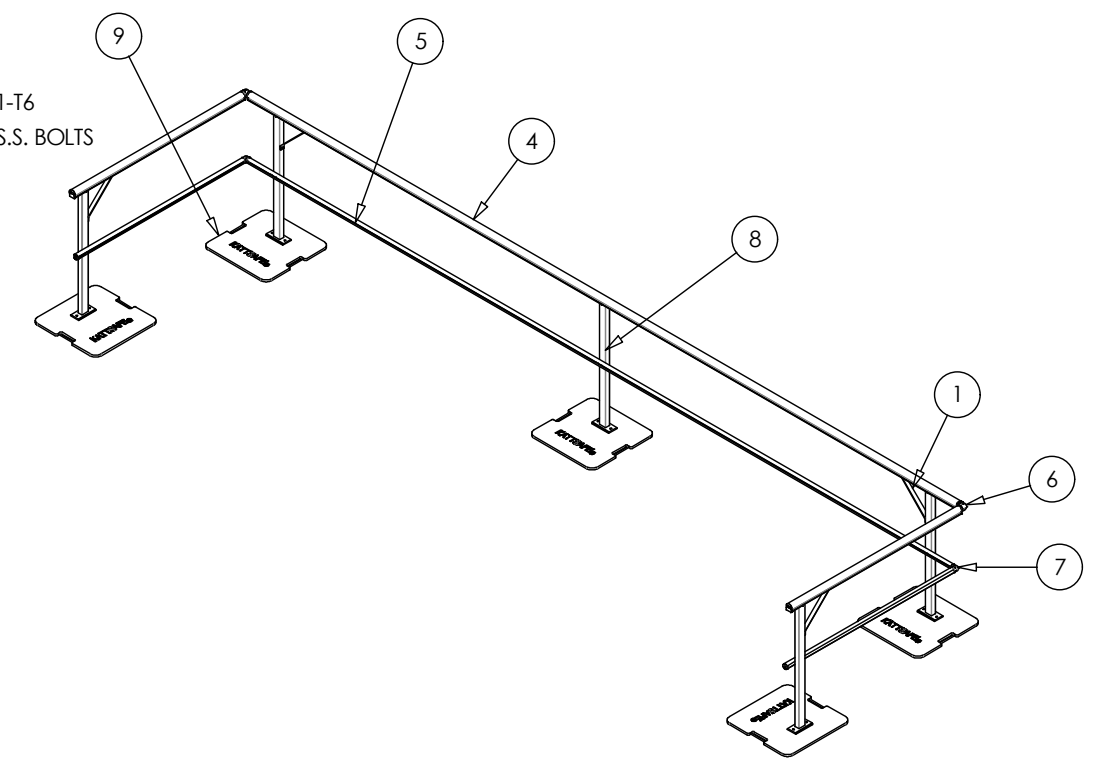

- NOTES:**
1. ALL HARDWARE IS TO BE STAINLESS STEEL
 2. INSTALLATION SHALL COMPLY WITH MANUFACTURER INSTRUCTIONS & OSHA REGULATIONS
 3. 90° RETURN RAIL KIT IS REQ. ON EACH END OF ANY RAILING RUN THAT IS HORIZONTAL WITH THE LEADING EDGE. RETURN KIT LENGTH TYP. 5 ft.
 4. WHERE HANDRAIL & KNEERAIL ARE JOINED, AN INTERNAL SPLICE IS REQ (SEE DWG FFUSA-1013)
 5. ALL CORNERS ARE TO BE JOINED BY KATTSAFE ADJUSTABLE HANDRAIL & KNEERAIL ELBOWS (SEE DWG FFUSA-1013)
 6. ALL EXPOSED HANDRAIL & KNEERAIL ENDS TO BE TERMINATED WITH END CAPS OR CLOSURE BENDS.

REV	DATE	BY	APP	COMMENTS
3	4/02/2019	SW	RP	UPDATED TITLE & PARTS LIST DESCRIPTION DETAILS
2	12/10/2017	RP	BV	RELEASED
1	6/10/2017	RP	WL	ISSUED FOR CHECKING

DRN: RP	DATE: 15/06/2017	SCALE 1 / 48 	UNTOLERANCED DIMENSIONS		
CHK: WL	DATE: 6/10/2017		DIMENSION	DIAMETER	LENGTH
APP: BV	DATE: 6/10/2017		0 - 250mm	± 0.25mm	± 0.5mm
			250 - 750mm	± 0.50mm	± 1.0mm
			> 750mm	± 0.75mm	± 1.5mm

FIXFASTUSA
 6210S INDIANAPOLIS ROAD
 WHITESTOWN IN 46075 USA
 T +1 317 769 7710
 F +1 317 769 5560
 E technical@fixfastusa.com
 W www.fixfastusa.com

Maximum safety. Minimum fuss.

THIS DRAWING REMAINS THE PROPERTY OF FIXFAST USA® AND MAY NOT BE CHANGED WITHOUT WRITTEN PERMISSION

DESCRIPTION KATTSAFE GR34 NON-PENETRATING GUARDRAIL		SHT # 1 / 1
MATERIAL	FINISH	SIZE B
DWG No. FFUSA-1004	FAB No.	REV 3