

"FLEXBEAM" STANDARD ACCESSORIES

 <p>REQ'D: _____ PCS. @ 3'-3" LG.</p>	 <p>REQ'D: _____ LIN. FT. (25' ROLL)</p>
<p>"FLEXBEAM" CLOSURES</p>	<p>2" x 2" UNIVERSAL CLOSURE</p>
 <p>REQ'D: _____ ROLLS @ 50'-0" LG.</p>	<p>SHEETING SCREWS</p>  <p>#12/14 x 1 1/2" SDWW REQ'D: _____ PCS.</p> <p>LAP & TRIM SCREWS</p>  <p>1/4-14 x 7/8" SDWW REQ'D: _____ PCS.</p>
<p>3/32" x 1/2" SEALER TAPE "ST1"</p>	<p>STANDARD FASTENERS</p>

NOTES:

- "FLEXBEAM" CLOSURES ARE A CLOSED CELL POLYETHYLENE FACTORY FORMED TO THE PANEL PROFILE AS SHOWN ABOVE.
- SEALER TAPE IS A NON-DRYING, NON-SKINNING, BUTYL BASE TAPE SUPPLIED IN 3/32" THICK x 1/2" WIDE x 50' ROLLS.
- FASTENERS ARE ZINC PLATED CARBON STEEL, 5/16" HEX HEAD, SELF DRILLING & SELF TAPPING METAL SCREWS. FASTENERS CAN BE SUPPLIED WITH PAINTED HEADS TO MATCH ROOFING OR SIDING.
- CONTACT FACTORY FOR PRICE AND AVAILABILITY OF NON-STANDARD ACCESSORIES.

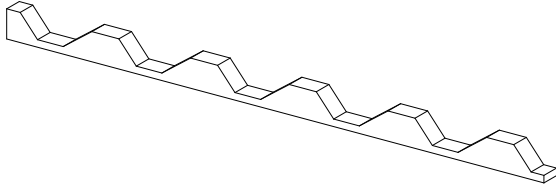
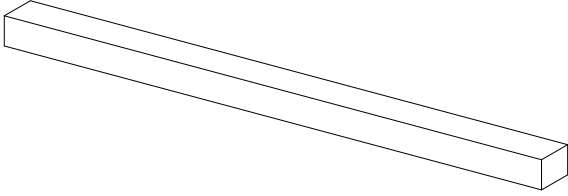
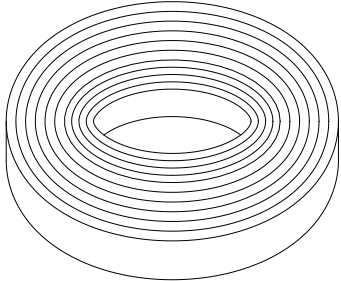
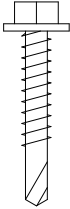
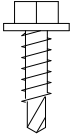

BOX 515 RAILROAD STREET
SANDY LAKE, PENNSYLVANIA 16145-0515
PHONE: 800-245-0396 ° FAX: 724-376-3864

"Flexbeam" Standard
Details

DRAWN BY: RW

DATE: 2/29/00

CHECKED BY: CANON

DATE:

"Flexbeam" Standard
Accessories

DRAWING NO.

flexbeam-1