

"WR1" BASE ROOF FLASH

PITCH	"A" ANGLE
1:12	95°
2:12	99°
3:12	104°
4:12	108°
5:12	113°

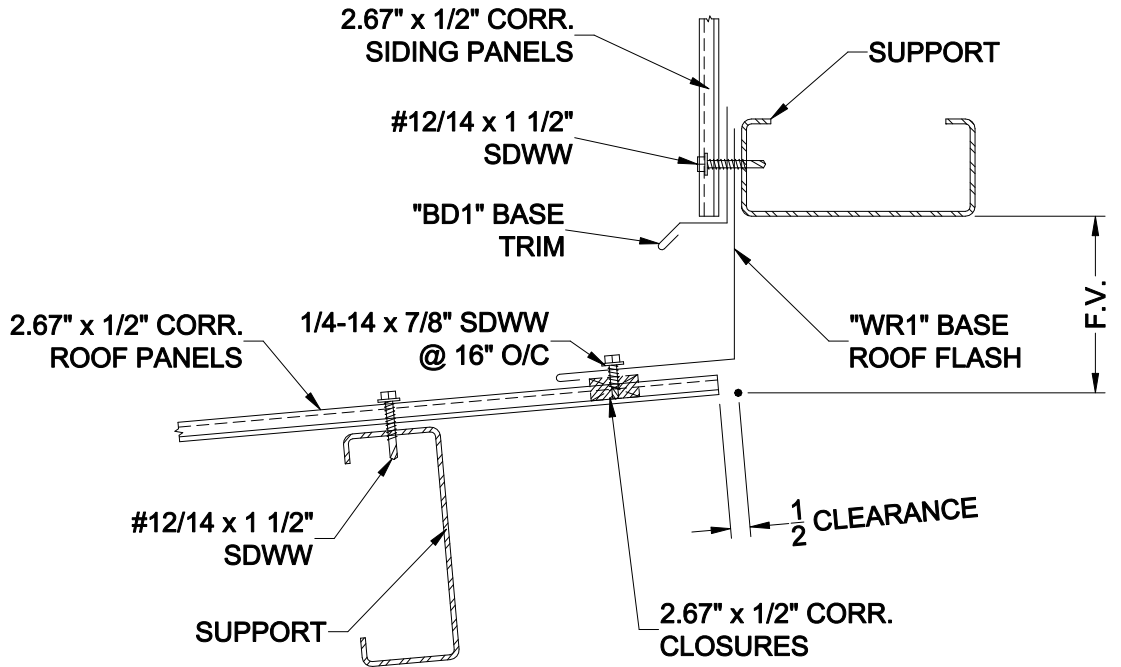

BASE ROOF (HALF RIDGE) DETAIL

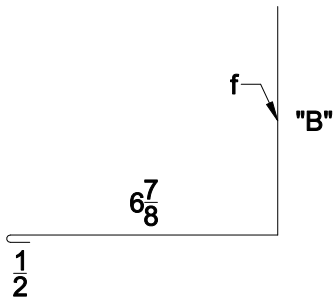

"SR1" BASE ROOF FLASH

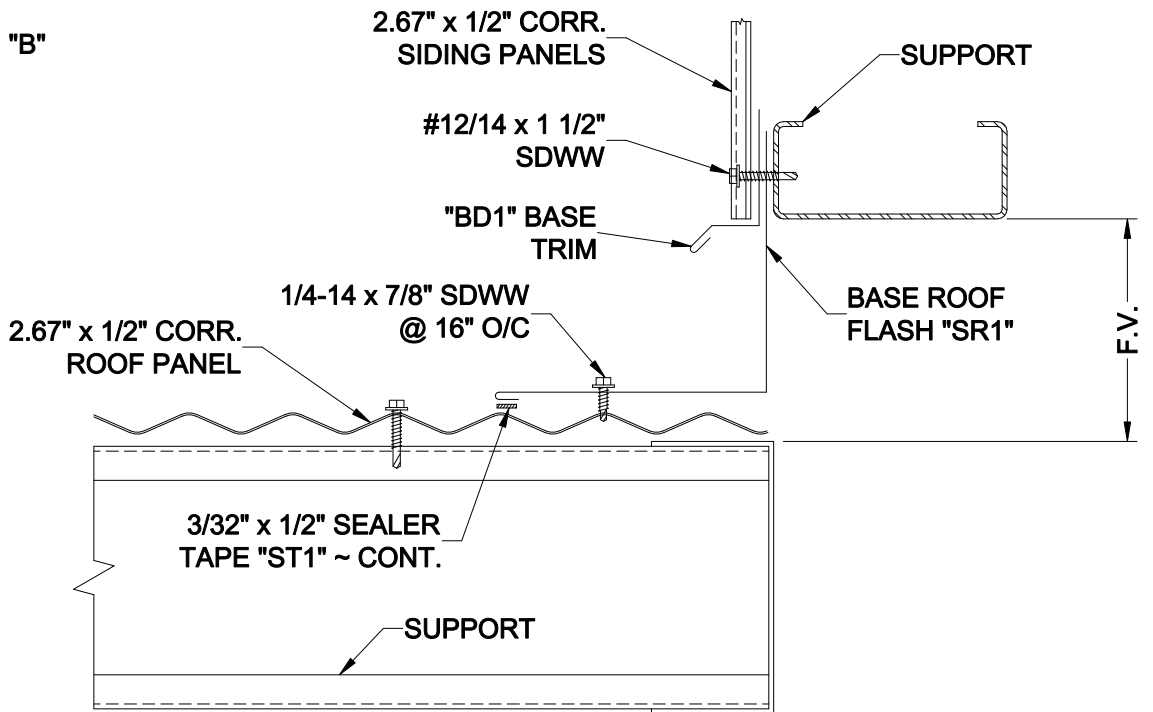

BASE ROOF DETAIL

"BD1" BASE TRIM

ERECTOR NOTES:

1. ENDS OF BASE ROOF FLASH SHOULD BE CAULKED AND LAPPED 4" AWAY FROM PREVAILING WIND. FLASHING SHOULD BE STITCHED TOGETHER AT ENDS USING TWO 1/4-14 x 7/8" SDWW FASTENERS.
2. "A" & "B" DIMENSIONS VARY DUE TO CONSTRUCTION VARIATIONS.



BOX 515 RAILROAD STREET
SANDY LAKE, PENNSYLVANIA 16145-0515
PHONE: 800-245-0396 ° FAX: 724-376-3864

2.67" x 1/2" Corrugated
Standard Details

Base Roof Details

DRAWN BY: RW

DATE: 2/14/00

DRAWING NO.

REVISED BY: CANON
K. Kemmer

DATE: 5-30-00

2.67" x 1/2" - 8