

FRONT VIEW II SCALE 1:5

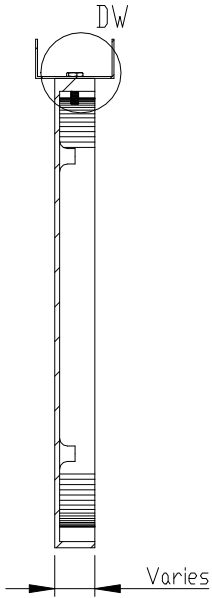

SECTION VIEW A-A II SCALE 1:5

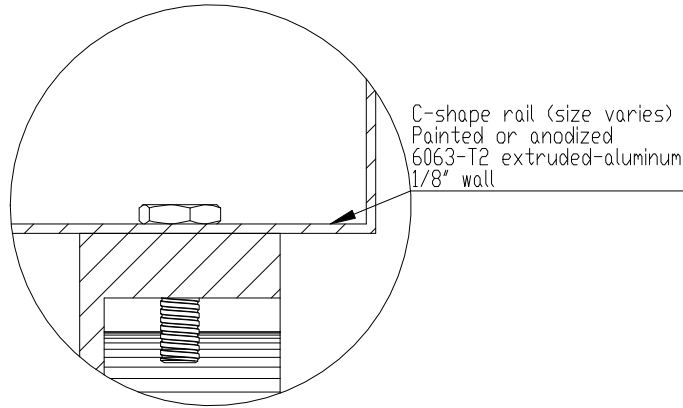

DETAIL DW II SCALE 1:1

NOTES:

- Letters 4"-24", Minimum 3/8" thick
- Tie back required (not supplied) on letters >8" high
- Letters are mounted by word. Maximum 96" length
- Standard catalog styles or customer per vector art. Flat faced/round/prismatic profile options. Typical 3/16" - 1/4" wall thickness on hollow back letters/logos.
- Letters or logos, standard or custom
- C-Channel (rail)
 - 1/2" deep x 1" or 1 1/2" wide x 96" long, painted or anodized
 - 1" deep x 2" or 3" wide x 96" long, painted or anodized
 - Rails pre-assembled for fit, large letters may ship loose
 - Minimum 2 studs per letter
 - Round letters (D, C, G, J, Q, S, U) sanded flat - optional
- Rail Mounting
 - C-channel rails are designed to be mounted to load bearing structures, holes and location to be determined by installer (rail mounting hardware not included)

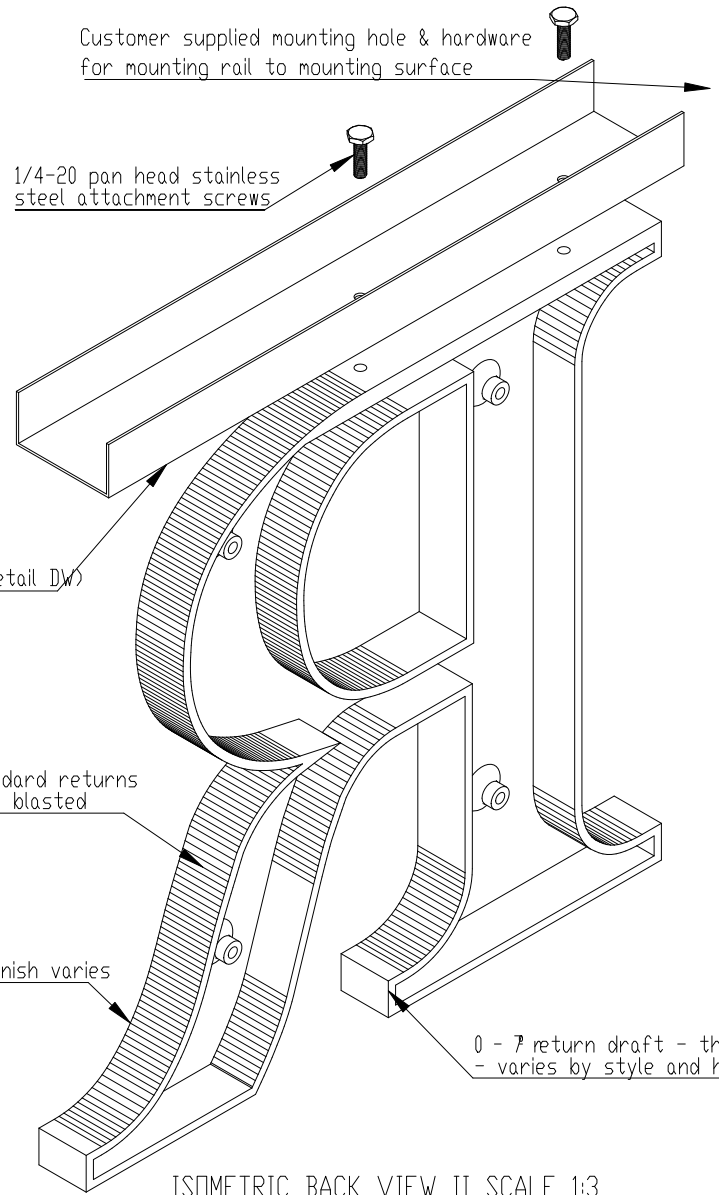

ISOMETRIC BACK VIEW II SCALE 1:3

TITLE: CAST METAL TOP RAIL MOUNT			
MATERIAL: ALUMINUM OR BRONZE		PRODUCT TYPE: CAST METAL	
DWG NO. CAST70	REV 01/20/17	SCALE: AS INDICATED	SHEET 1 OF 1