

18 gauge face material - up to 24" high - All strokes
 18 gauge face material - over 24" high - up to 8" stroke
 16 gauge face material - over 24" high - over 8" stroke

Letter finish varies

Lead free continous solder inside face

Strap soldered to inside of return (optional: recessed strap to face)

Threaded studs

Stainless steel strap (see detail DW)

24 gauge return material - up to 24" high
 22 gauge return material - over 24" high

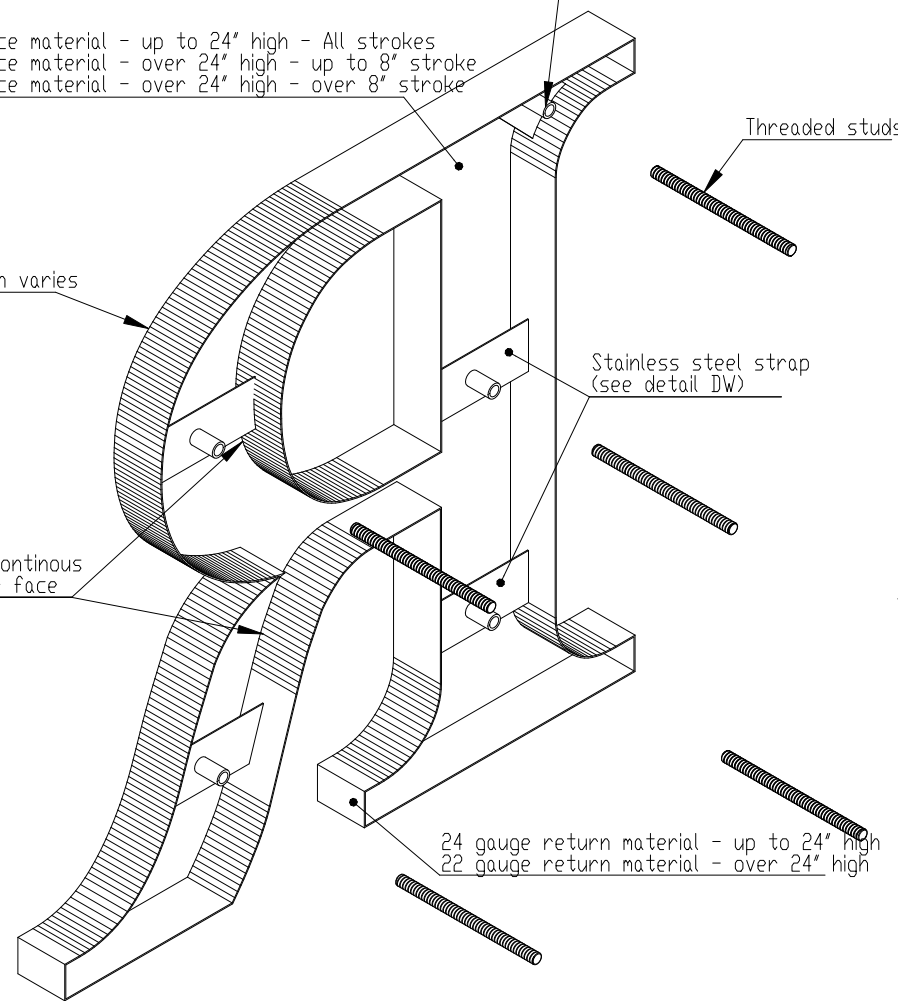

Threaded stud boss welded to strap
 Size varies (see table)

Stainless steel mounting stud
 Size varies (see table)

Optional spacer sleeve (size varies)

Stainless steel strap

LETTER SIZE	STUD BOSS
6" to 24"	10 -24
over 24"	1/4 - 20

NOTES:
 - Min. 3/8" stroke
 - 2"- 4" high, return grain will be in long direction

MATERIAL OPTIONS
 Standard - 304 prefinished stainless steel
 Optional - 316 prefinished stainless steel (more corrosion resistant)
 - 304 prefinished stainless with titanium coating



TITLE: METAL FACE NO BACK - STRAP MOUNT			
MATERIAL: STAINLESS STEEL		PRODUCT TYPE: FABRICATED METAL	
DWG NO. FABL20	REV. 03/13/17	SCALE: AS INDICATED	SHEET 1 OF 1