

PRODUCT CONSTRUCTION EXAMPLE

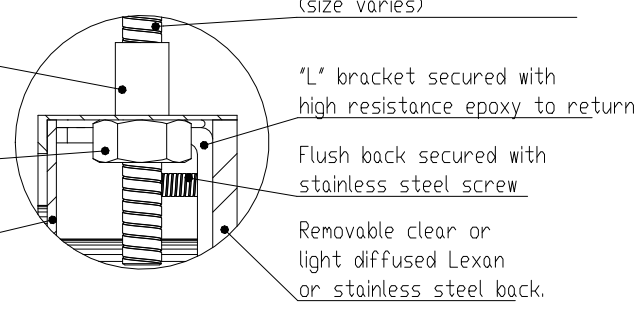
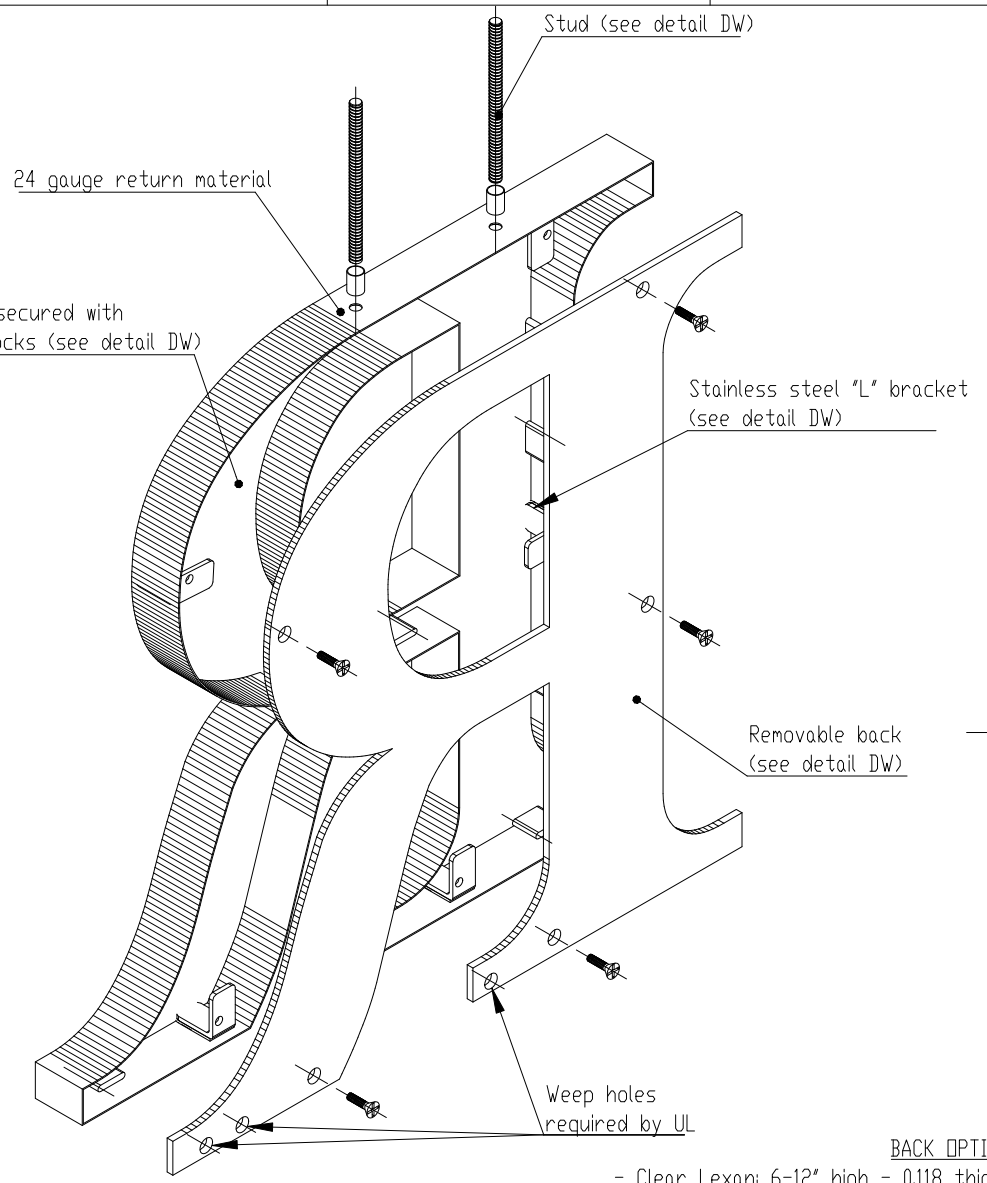
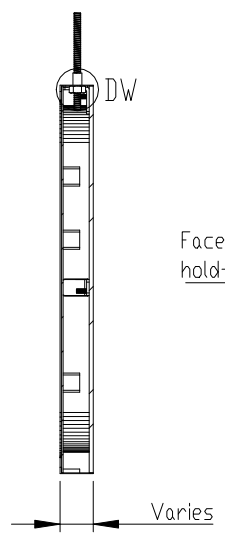
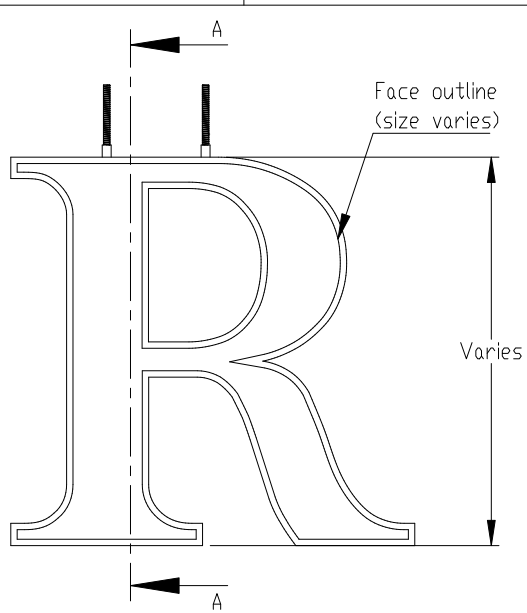

NOTE: This mounting option is recommended for interiors only

INSERT OPTIONS	
Stainless steel	18-20 gauge up to 24" high
Acrylic	3/16" thick - up to 36" high

MATERIAL OPTIONS
 Standard - 304 prefinished stainless steel
 Optional - 316 prefinished stainless steel (more corrosion resistant)
 - 304 prefinished stainless with titanium coating



BACK OPTIONS

- Clear Lexan: 6-12" high - 0.118 thick
- Light diffused Lexan: 0.177" thick
- Stainless steel - same gauge as face

TITLE: CUT OUT FACE WITH INSERT WITH BACK - TOP STUD MOUNT

MATERIAL: STAINLESS STEEL	PRODUCT TYPE: FABRICATED METAL
------------------------------	-----------------------------------