

PRODUCT CONSTRUCTION EXAMPLE

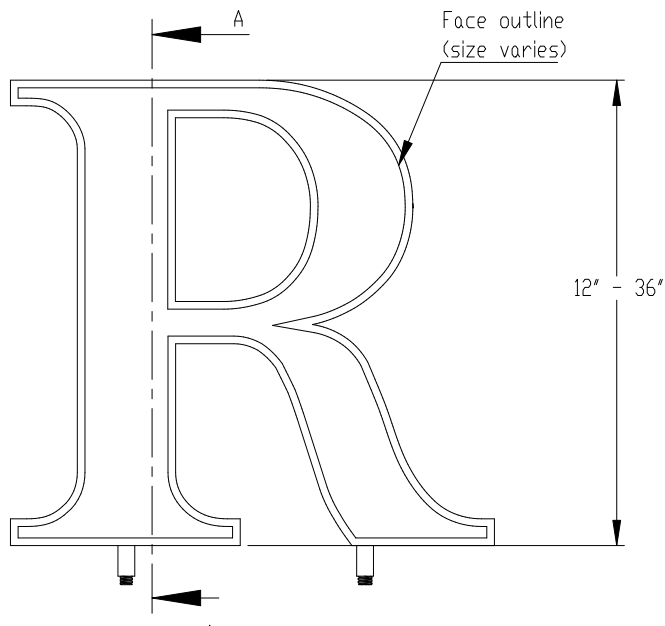

FRONT VIEW II SCALE 1:5

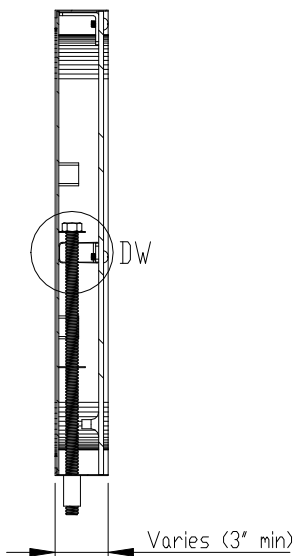

SECTION A-A II SCALE 1:5

24 gauge return material - 12" to 24" high
 22 gauge return material - over 24" high

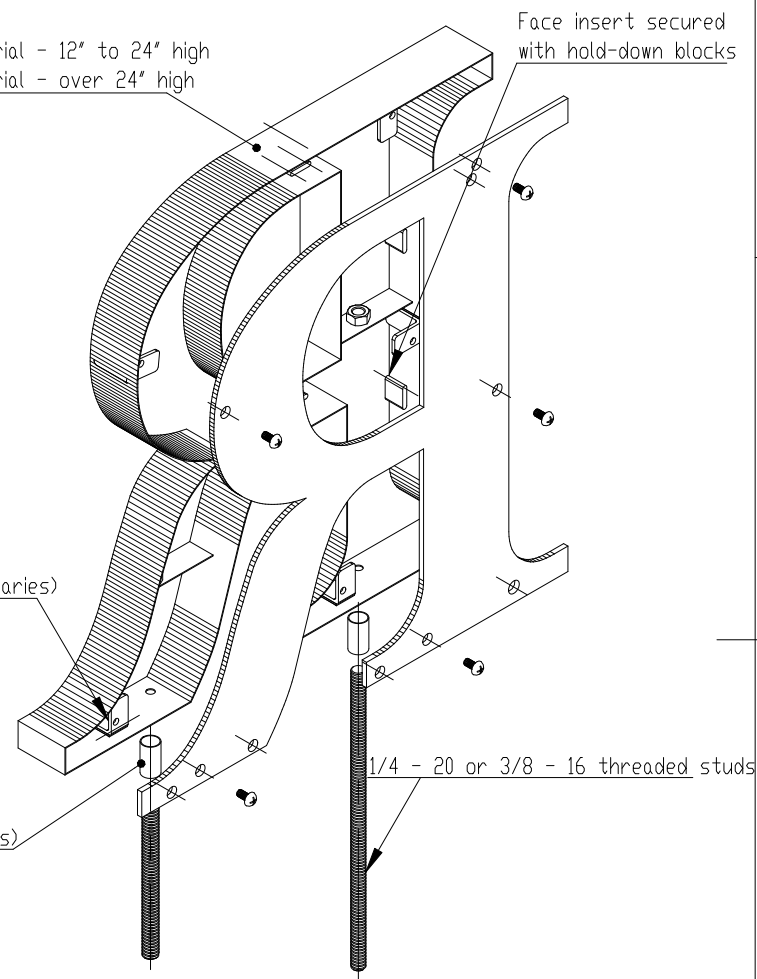

ISOMETRIC BACK VIEW II SCALE 1:4

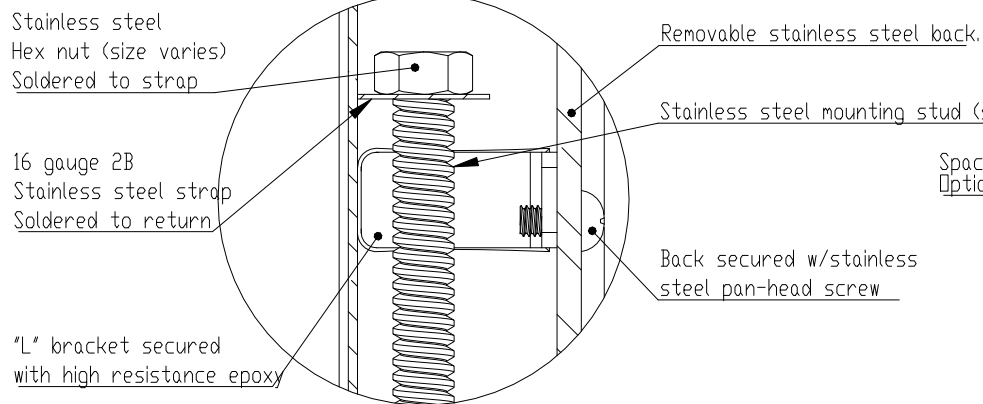

DETAIL DW II SCALE 1 : 1

INSERT OPTIONS	
Stainless steel	18-20 gauge up to 24" high
	16-18 gauge over 24" to 36" high
Acrylic	3/16" thick - up to 36" high

NOTES:

- Tie backs required (not supplied) on letters > 8" high

MATERIAL OPTIONS

Standard - 304 prefinished stainless steel

Optional - 316 prefinished stainless steel (more corrosion resistant)

- 304 prefinished stainless with titanium coating

- NOTES:
- Lexan back - Flush stainless steel screw
 - Metal back - Pan-head screw slightly recessed



TITLE: CUT OUT FACE WITH INSERT - WITH BACK FOR LEDS - ENGINEERED STUD MOUNT

MATERIAL: STAINLESS STEEL

PRODUCT TYPE: FABRICATED METAL