

PRODUCT CONSTRUCTION EXAMPLE

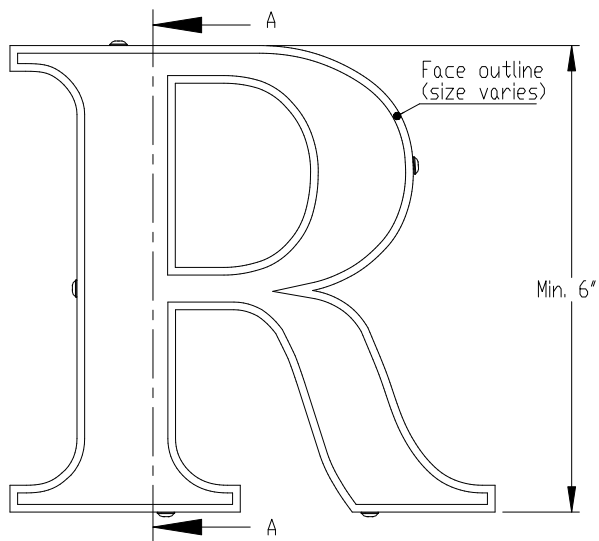

FRONT VIEW II SCALE 1:5

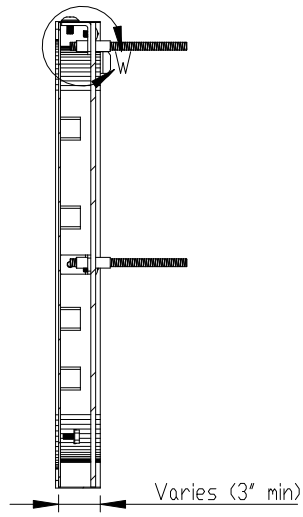

SECTION VIEW A-A II SCALE 1:5

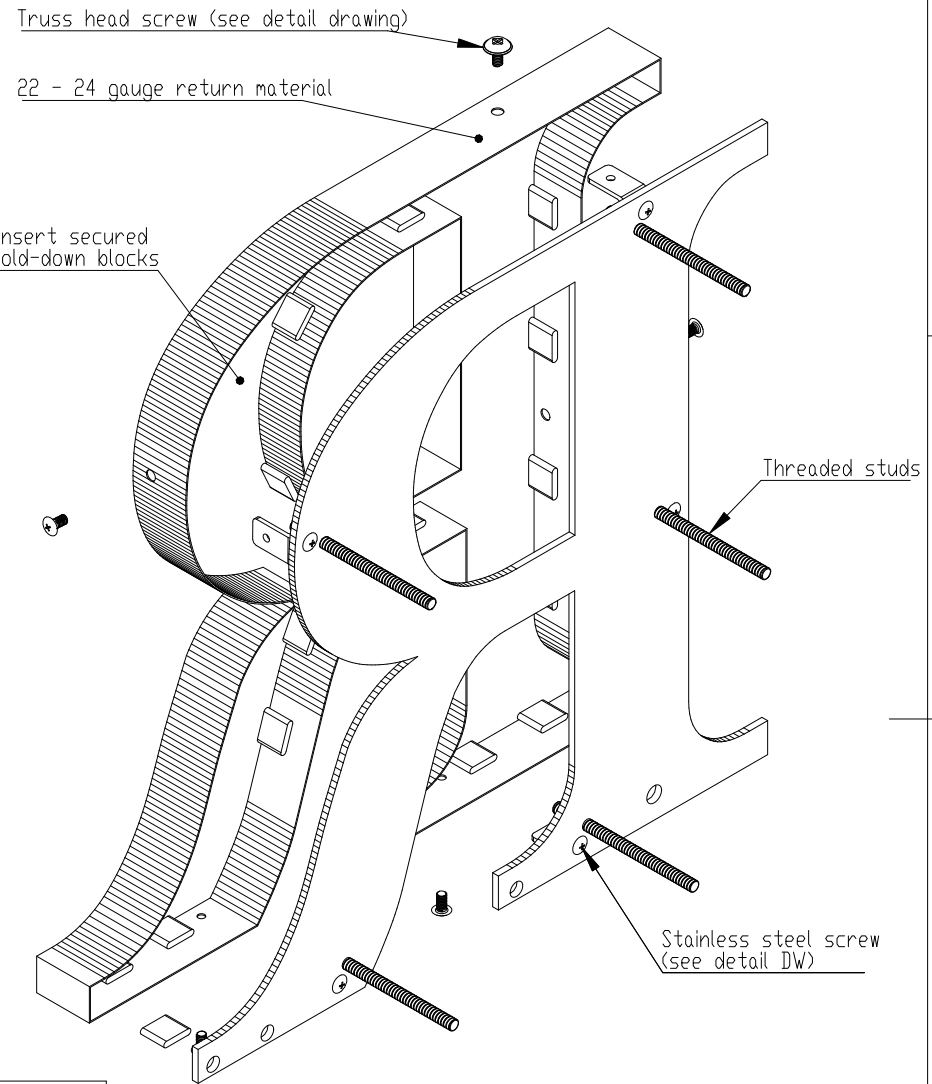

ISOMETRIC BACK VIEW II SCALE 1:3

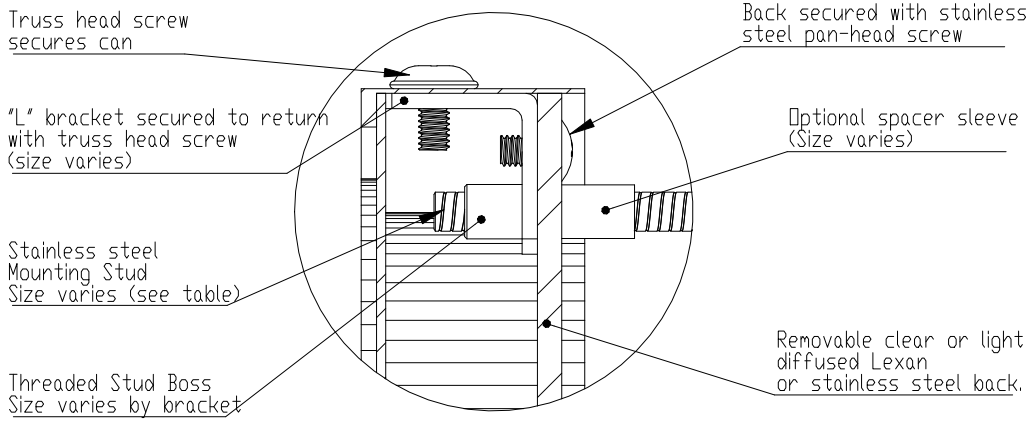

DETAIL DW II SCALE 1:1

LETTER SIZE	MIN. DEPTH	STUD	BRACKET
6" to 24"	1.0"	10 - 24	Medium
over 24"	1.75"	1/4 - 20	Large

- Notes:
- Metal back - Pan-head slightly recessed
  - Lexan back - Flush stainless steel screw
  - Tie backs required (not supplied) on letters > 8' high

INSERT OPTIONS	
Stainless steel	18-20 gauge up to 24" high
Stainless steel	16-18 gauge over 24" to 36" high
Acrylic	3/16" thick - up to 36" high

- MATERIAL OPTIONS
- Standard - 304 prefinished stainless steel
  - Optional - 316 prefinished stainless steel (more corrosion resistant)
  - 304 prefinished stainless with titanium coating



TITLE: CUT OUT FACE WITH INSERT - WITH BACK FOR LEDS - REMOVABLE CAN MOUNT

MATERIAL: STAINLESS STEEL      PRODUCT TYPE: FABRICATED METAL