

PRODUCT CONSTRUCTION EXAMPLE

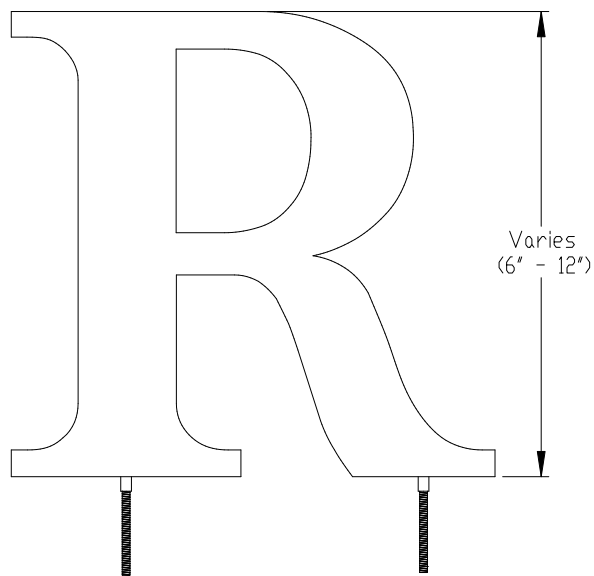

FRONT VIEW II SCALE 1:5

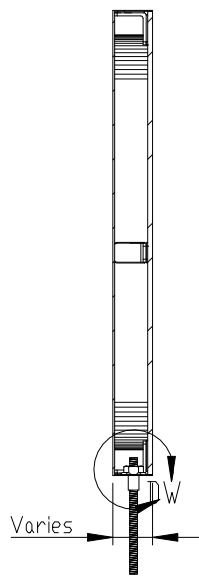

SECTION VIEW A-A II SCALE 1:5

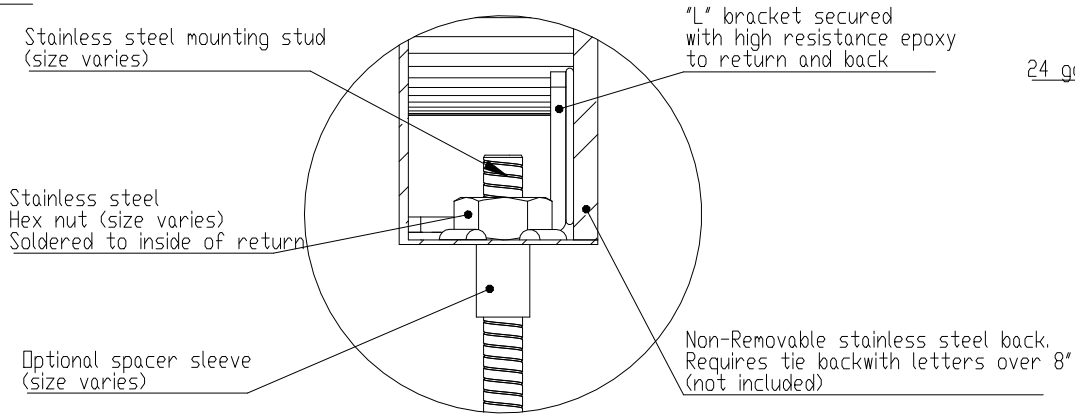

DETAIL DW II SCALE 1:1

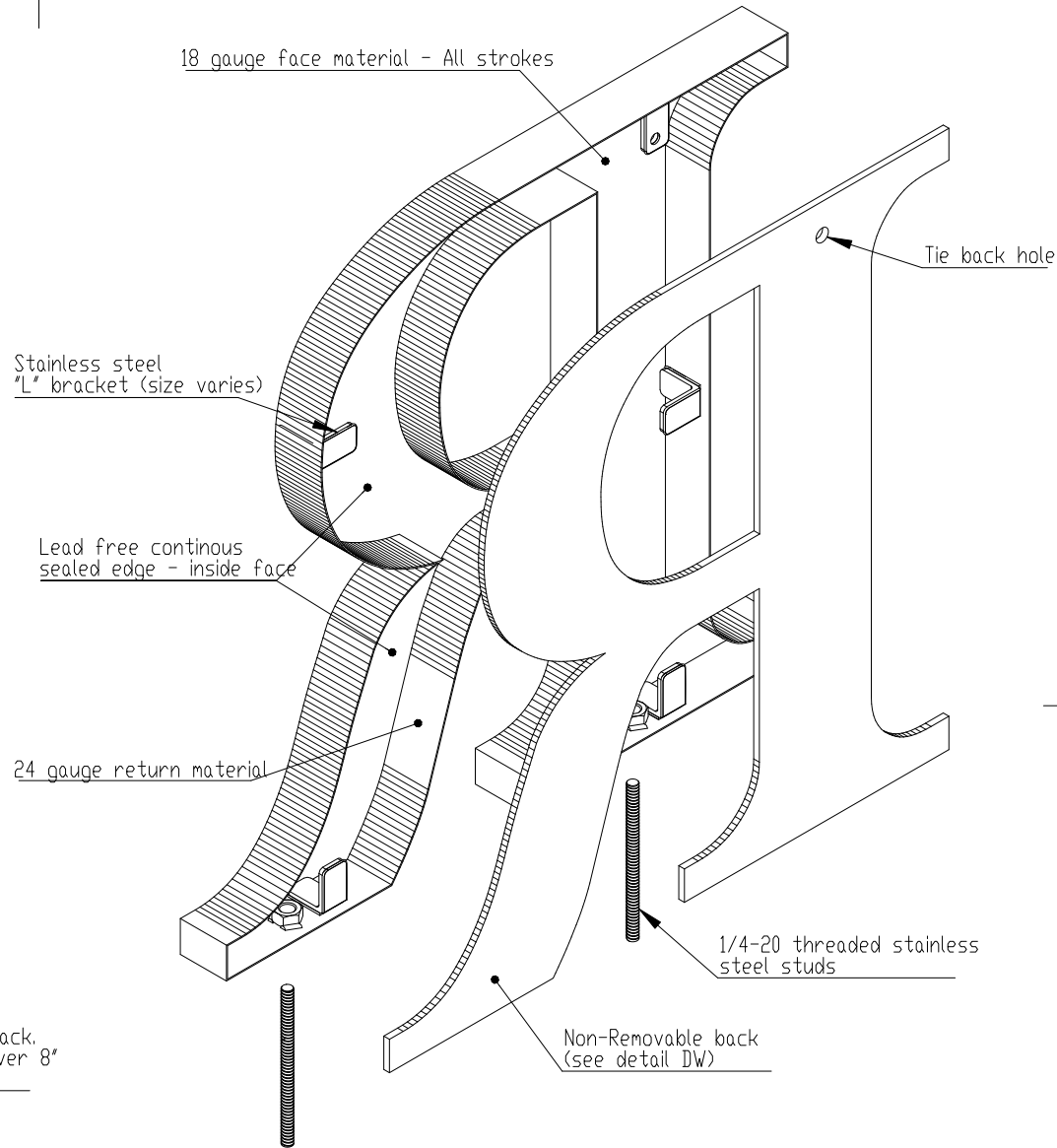

ISOMETRIC BACK VIEW II SCALE 1:3

- NOTES:**  
 - Tie backs required (not supplied) on letters > 8" high  
**BACK OPTIONS**  
 - Stainless steel - same gauge as face.  
**MATERIAL OPTIONS**  
 Standard - 304 prefinished stainless steel  
 Optional - 316 prefinished stainless steel (more corrosion resistant)  
           - 304 prefinished stainless with titanium coating



TITLE: METAL FACE WITH NON-REMOVABLE BACK BOTTOM STUD MOUNT			
MATERIAL: STAINLESS STEEL		PRODUCT TYPE: FABRICATED METAL	
DWG NO. FABL270	REV 12/2/16	SCALE: AS INDICATED	SHEET 1 OF 1