

PRODUCT CONSTRUCTION EXAMPLE

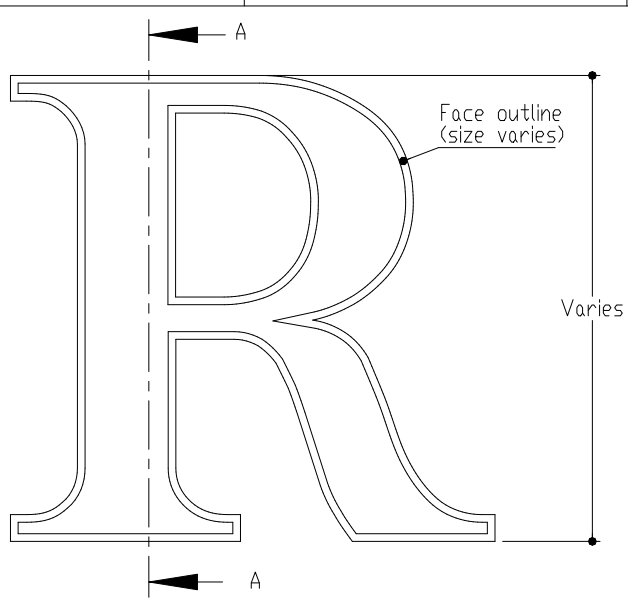

FRONT VIEW II SCALE 1:5

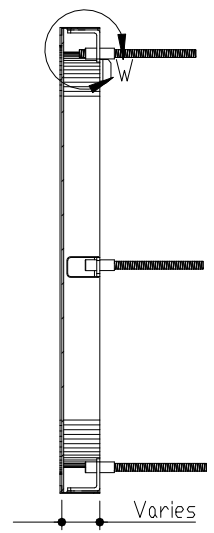

SECTION A-A II SCALE 1:5

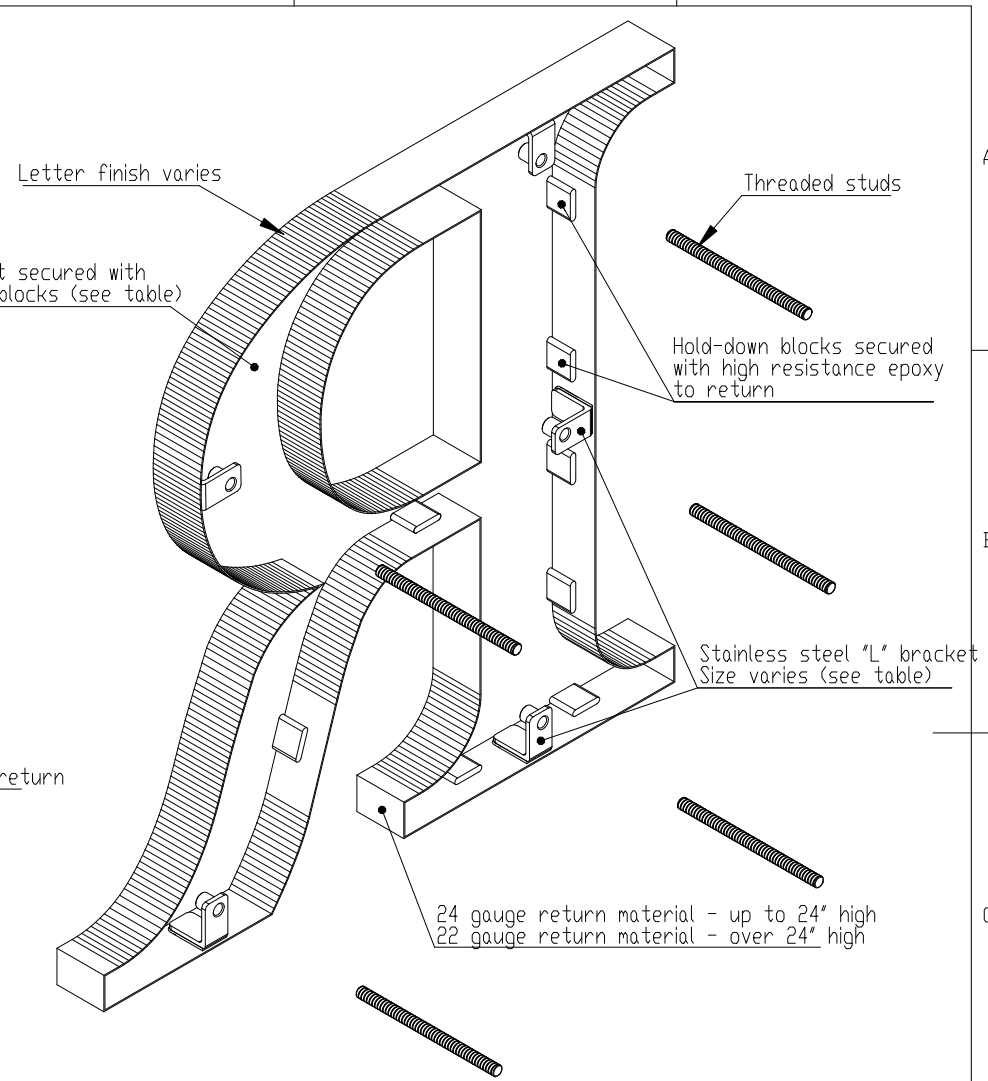

ISOMETRIC BACK VIEW II SCALE 1:3

Stainless steel mounting Stud  
Size varies (see table)

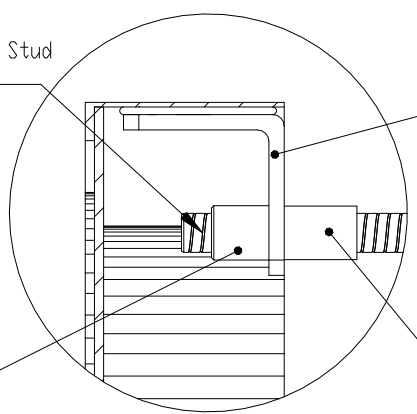

DETAIL DW II SCALE 1:1

Threaded Stud Boss  
Size varies by bracket

Optional spacer sleeve  
(Size varies)

INSERT OPTIONS	
Stainless steel	18-20 gauge up to 24" high 16-18 gauge over 24" to 36" high
Acrylic	3/16" thick - up to 36" high

LETTER SIZE	MIN. DEPTH AND STROKE		BRACKET	STUD
up to 6"	0.6"	15 mm	Small	6 - 32
over 6" to 24"	1.0"	25.4 mm	Medium	10 - 24
over 24"	1.75"	44.5 mm	Large	1/4 - 20

NOTES:  
- Letter stroke must be 50% of depth  
Ex: A 2" deep letter needs a 1" min. stroke

MATERIAL OPTIONS  
Standard - 304 prefinished stainless steel  
Optional - 316 prefinished stainless steel (more corrosion resistant)  
- 304 prefinished stainless with titanium coating



TITLE: CUT OUT FACE WITH INSERT-NO BACK - SIDE MOUNT

MATERIAL: STAINLESS STEEL      PRODUCT TYPE: FABRICATED METAL