

PRODUCT CONSTRUCTION EXAMPLE

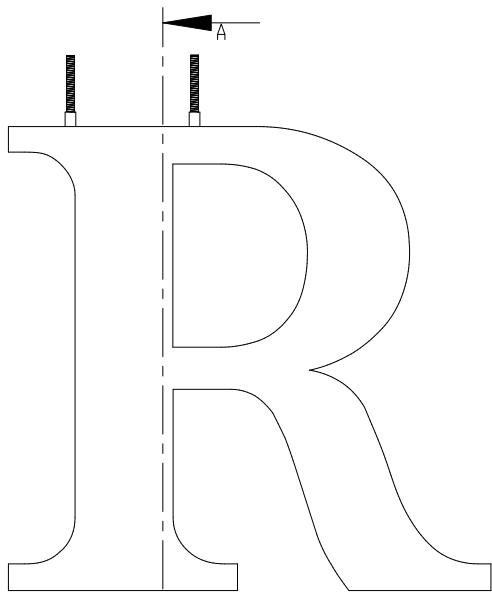

FRONT VIEW II SCALE 1:5

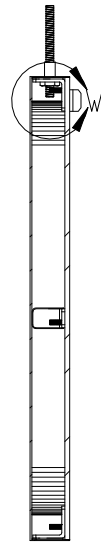

SECTION VIEW A-A II SCALE 1:5

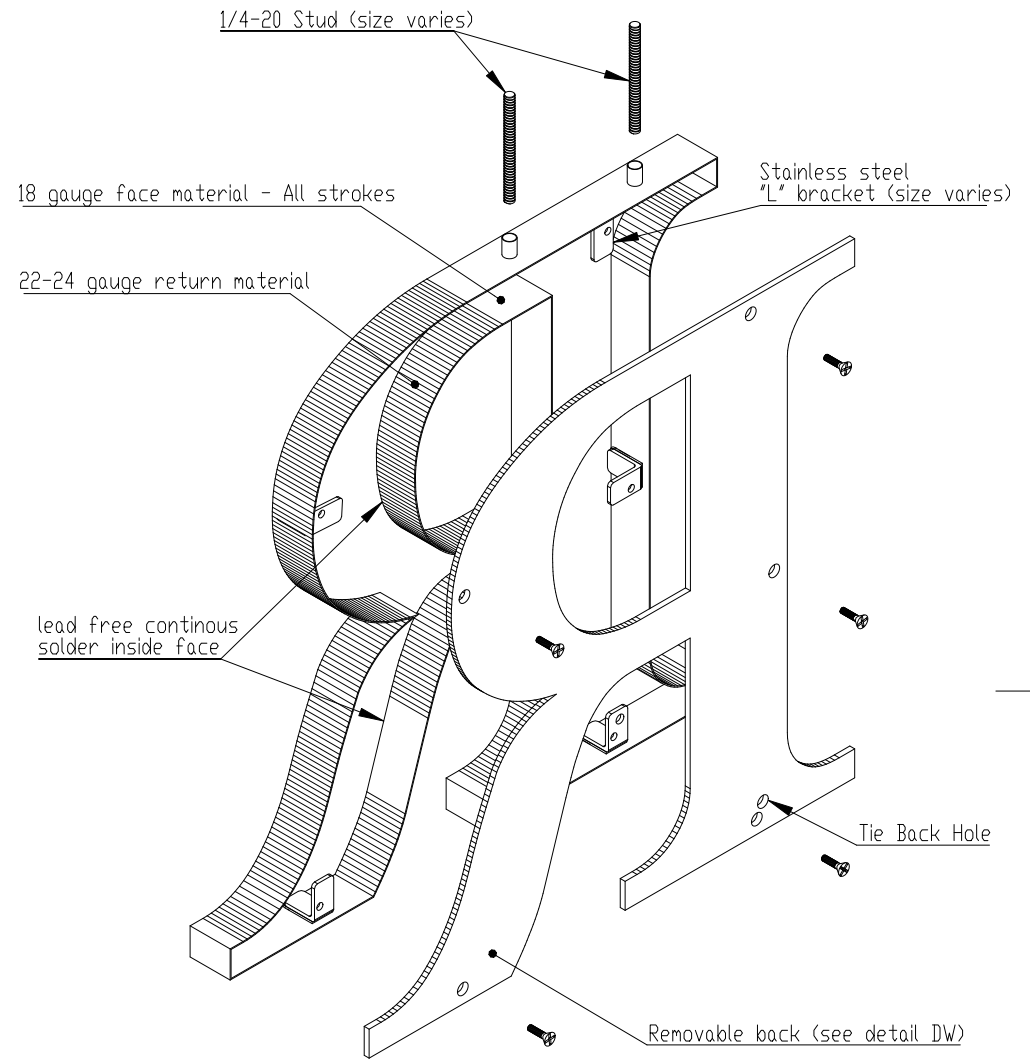

ISOMETRIC BACK VIEW II SCALE 1:3.5

Optional spacer sleeve (size varies)

Removable clear or light diffused Lexan or stainless steel back.

Stainless steel Hex nut (size varies)
Soldered to inside of return

Flush back secured with stainless steel screw

Stainless steel mounting stud (size varies)

"L" bracket secured with high resistance epoxy

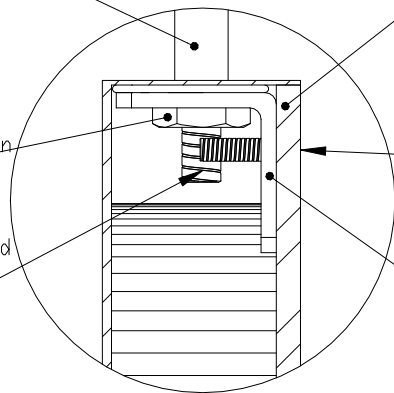

DETAIL DW II SCALE 1:1

BACK OPTIONS

- Clear Lexan: 6-12" high - 0.118 thick
- Light diffused Lexan: 0.177" thick
- Stainless steel - same gauge as face

MATERIAL OPTIONS

- Standard - 304 prefinished stainless steel
- Optional - 316 prefinished stainless steel (more corrosion resistant)
- 304 prefinished stainless with titanium coating



TITLE:

METAL FACE WITH BACK - TOP MOUNT

MATERIAL:

STAINLESS STEEL

PRODUCT TYPE:

FABRICATED METAL

DWG NO. FABL70

REV 11/21/16

SCALE: AS INDICATED

SHEET 1 OF 1