

EXAMPLE CONSTRUCTION EXAMPLE

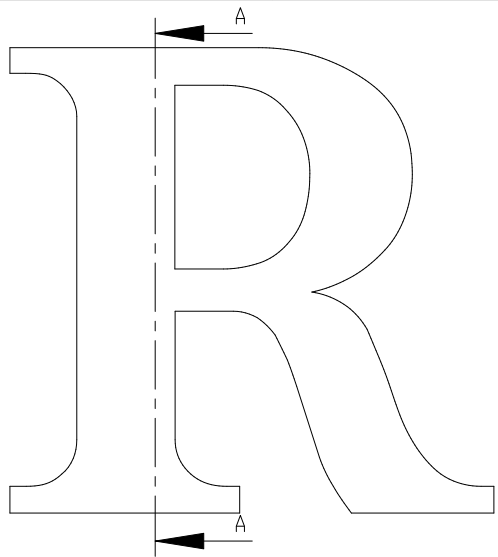

FRONT VIEW II SCALE 1:5

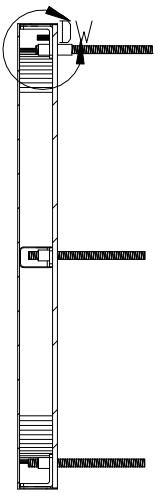

SECTION A-A II SCALE 1:5

18 gauge face material - up to 24" high - All strokes  
 18 gauge face material - over 24" high - up to 8" stroke  
 16 gauge face material - over 24" high - over 8" stroke

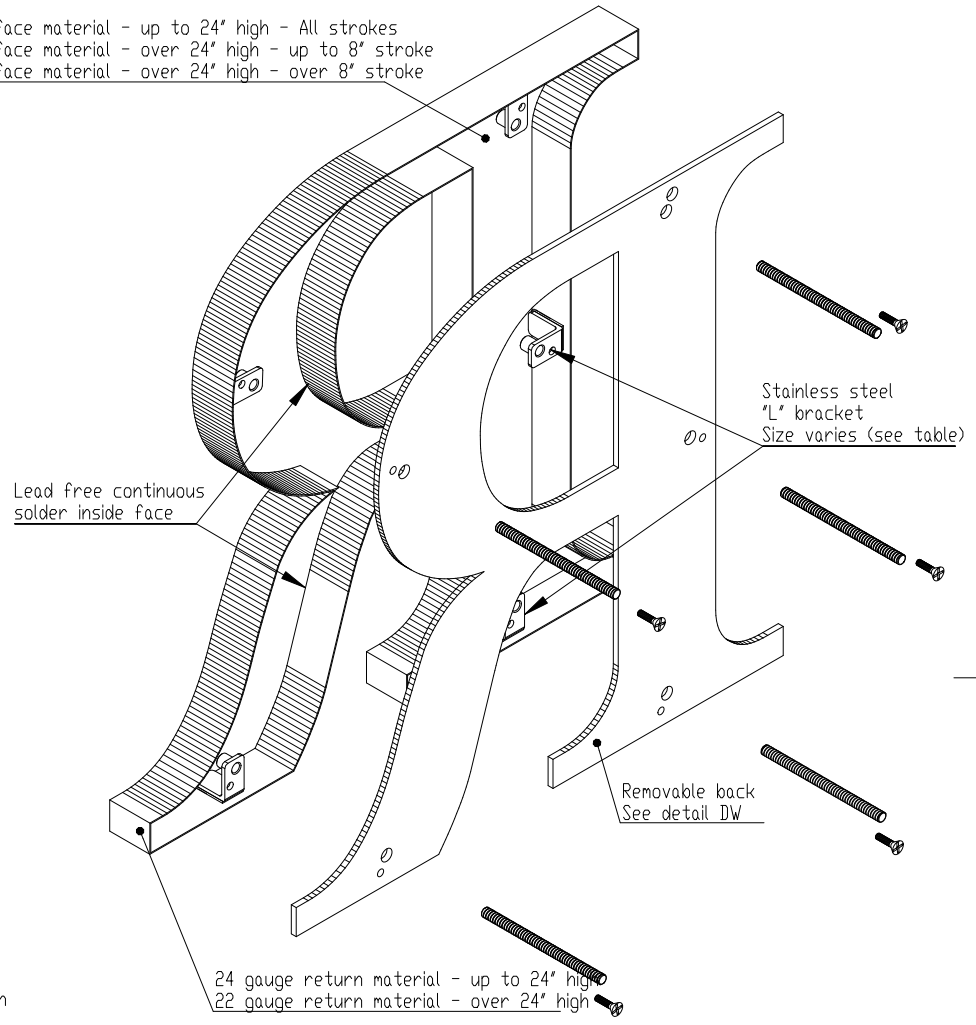

ISOMETRIC BACK VIEW II SCALE 1:3

"L" bracket secured with high resistance epoxy to return

Stainless steel screw secures back

Stainless steel Mounting Stud Size varies (see table)

Optional spacer sleeve (Size varies)

Threaded Stud Boss Size varies by bracket

Removable clear or light diffused Lexan or stainless steel back.

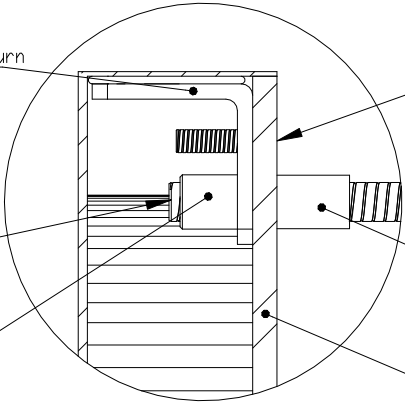

DETAIL DW II SCALE 1:1

BACK OPTIONS  
 - Light diffused Lexan: 0.177" thick  
 - Stainless steel - same gauge as face  
 - Clear Lexan: 6-24" high - 0.118 thick, over 24" - 0.236" thick

LETTER SIZE	MIN. DEPTH	STUD	BRACKET
up to 6"	0.6"	6 - 32	Small
over 6" to 24"	1.0"	10 - 24	Medium
over 24"	1.75"	1/4 - 20	Large

MATERIAL OPTIONS  
 Standard - 304 prefinished stainless steel  
 Optional - 316 prefinished stainless steel (more corrosion resistant)  
 - 304 prefinished stainless with titanium coating



TITLE: METAL FACE WITH BACK - SIDE MOUNT			
MATERIAL: STAINLESS STEEL		PRODUCT TYPE: FABRICATED METAL	
DWG NO. FABL80	REV 11/21/16	SCALE: AS INDICATED	SHEET 1 OF 1