

PRODUCT CONSTRUCTION EXAMPLE

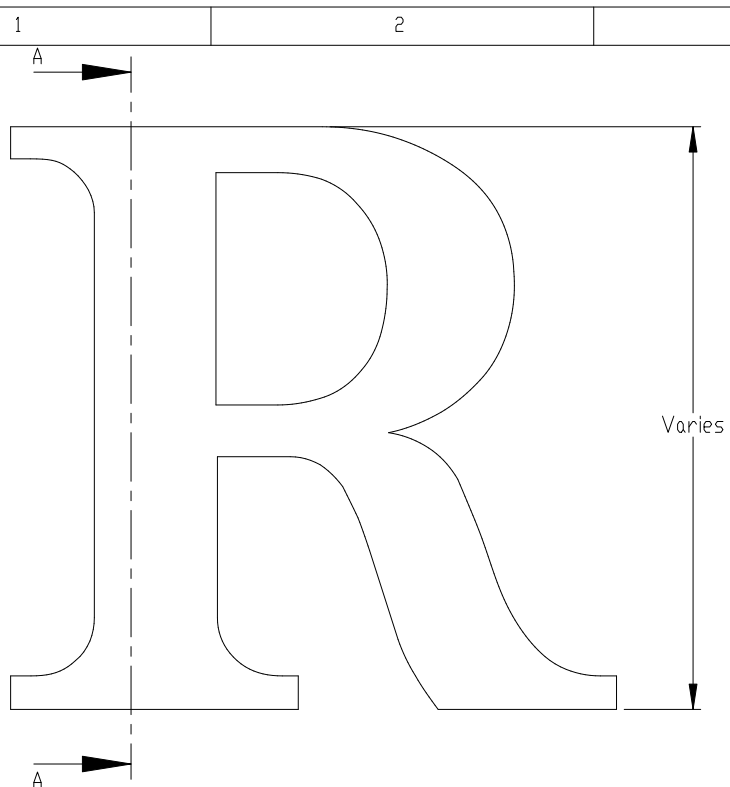

FRONT VIEW II SCALE 1:2

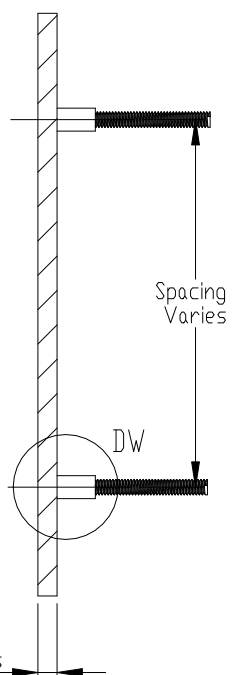

SECTION A-A II SCALE 1:2

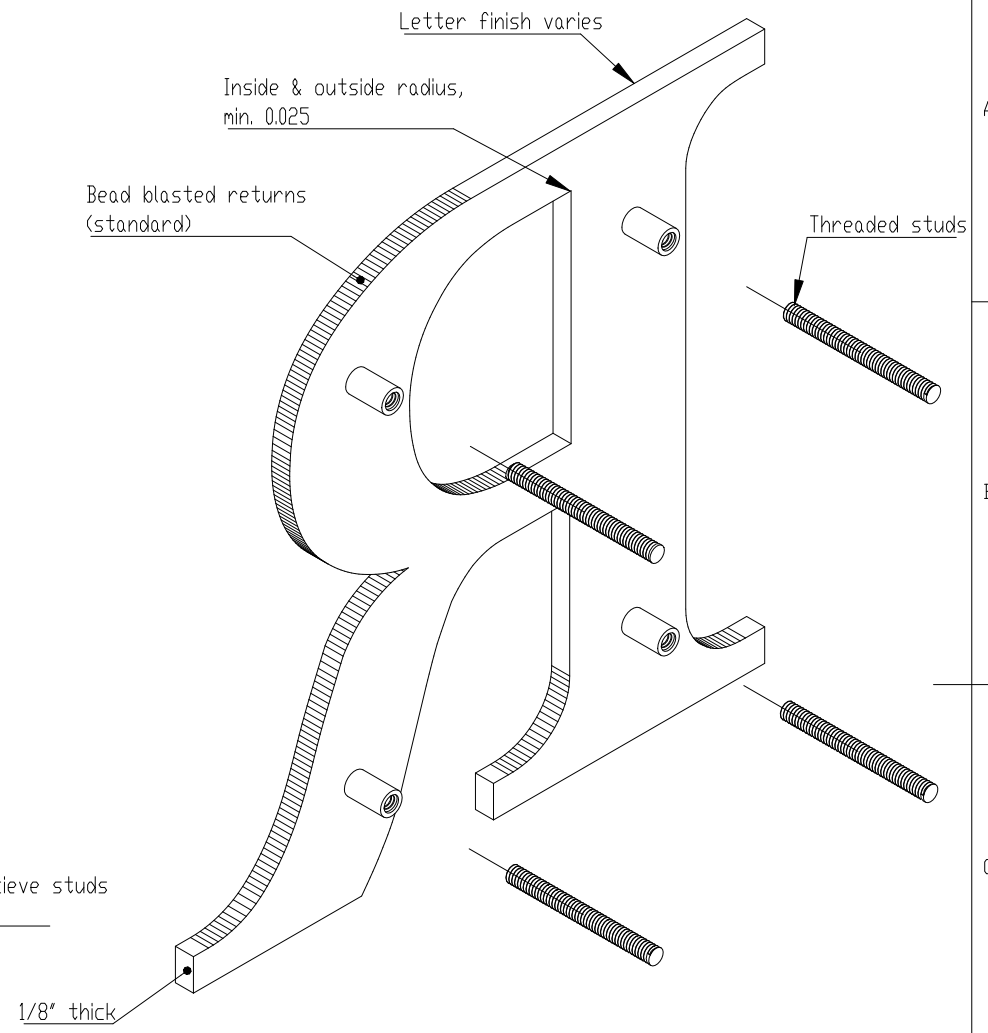

ISOMETRIC BACK VIEW II SCALE 1:1.5

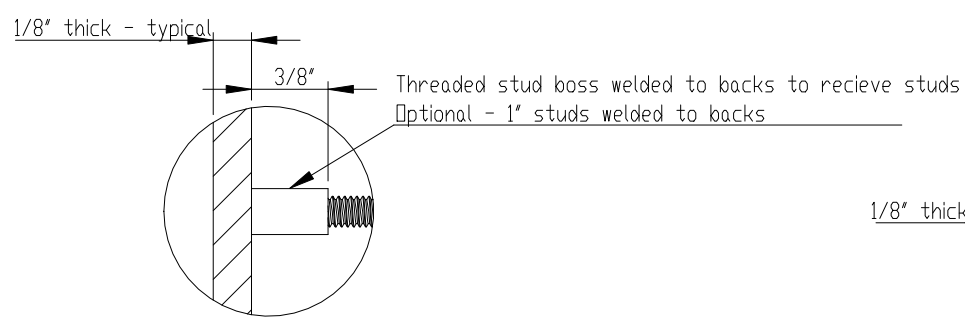

DETAIL DW II SCALE 1 : 1

NOTES:

- Multiple face finish options
- 6/32 or 10/24 welded stud boss or 1" studs
- Optional spacer for studs
- Min. 1/2" letter stroke
- Aluminum stud boss for aluminum letters
- Stainless steel for stainless letters, copper base boss on red metals
- Designed for use on 1/8" thick metal letters
- Letters or logos, standard or custom



| | | | |
|---|--------------|---------------------------------|--------------|
| TITLE: FLAT CUT METAL - WELDED STUD/BOSS MOUNT | | | |
| MATERIAL: METAL | | PRODUCT TYPE: FLAT CUT METAL | |
| DWG NO. FTMT100 | REV 10/25/16 | SCALE: AS INDICATED | SHEET 1 OF 1 |