

PRODUCT CONSTRUCTION EXAMPLE

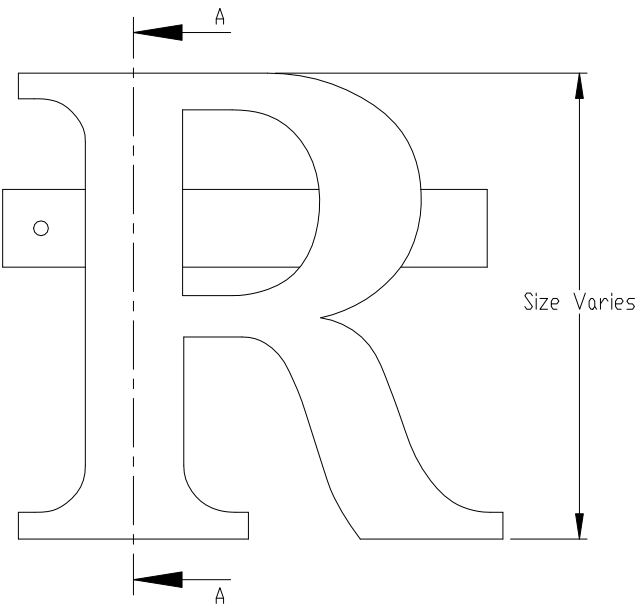

FRONT VIEW II SCALE 1:2.5

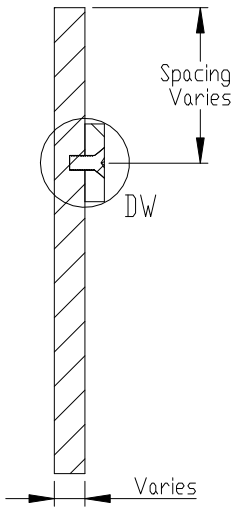

SECTION A-A II SCALE 1 : 2.5

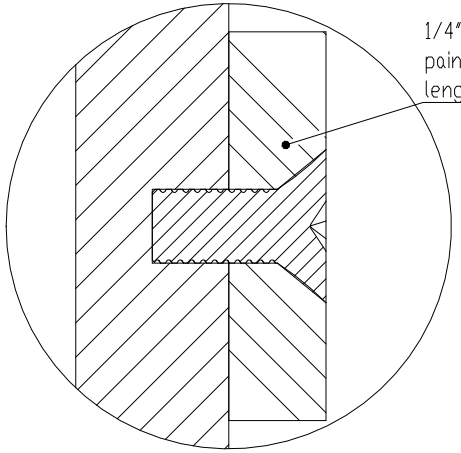

DETAIL DW II SCALE 2 : 1

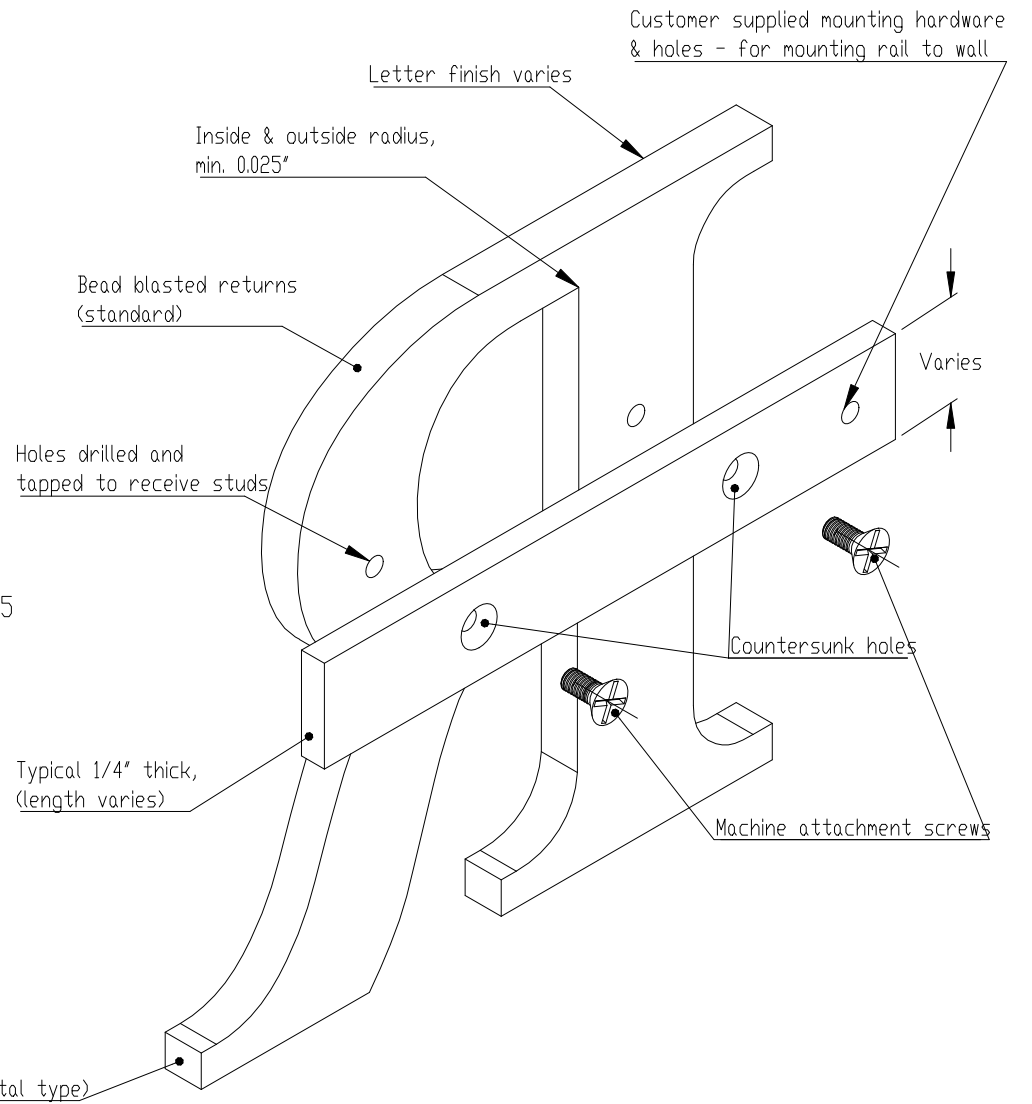

ISOMETRIC BACK VIEW II SCALE 1:1.5

NOTES:

- 4" - 8" high letters, typical
- Minimum 1/4" thick letters (optional gauge based on metal type)
- Optional - Letter back finished or unfinished.
- Letters pre-assembled to rails to ensure fit- larger letters shipped loose
- Min. 2 screws per letter
- Flat 1/4" thick aluminum rails - standard, optional c-channel, painted or anodized
- Max 95" long x 1/4", 1/2", 3/4" or 1" wide
- 10/24 or 1/4-20 stainless steel attachment screws
- Metal Rails are designed to be mounted to load bearing structures, holes and location to be determined by installer (rail mounting hardware and holes not included)
- Letters or logos, standard or custom



TITLE: FLAT CUT METAL - SINGLE RAIL MOUNT			
MATERIAL: METAL		PRODUCT TYPE: FLAT CUT METAL	
DWG NO. FTMT50	REV. 10/25/16	SCALE: AS INDICATED	SHEET 1 OF 1