

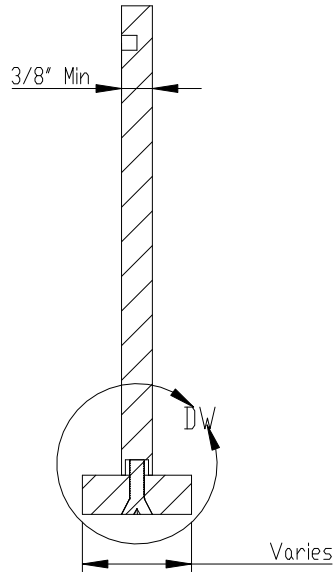

FRONT VIEW II SCALE 1:2.5

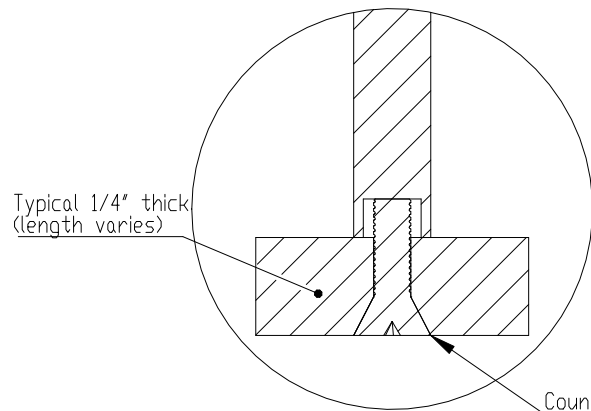

SECTION VIEW A-A II SCALE 1:2.5



DETAIL DW II SCALE 2:1

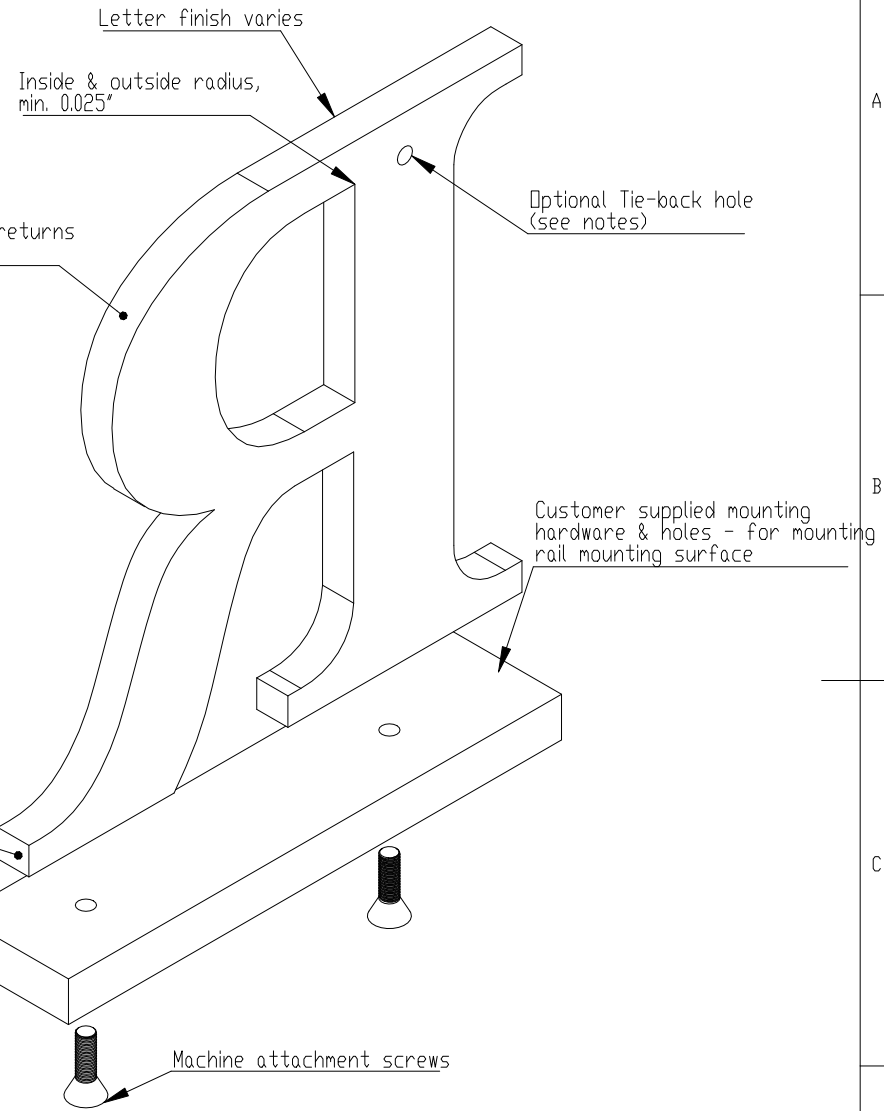

ISOMETRIC BACK VIEW II SCALE 1:1.75

NOTES:

- 4" - 24" high letters
- Minimum 3/8" thick letters
- Tie back required (not supplied) on letters > 8" high
- Bottom of round letters may be sanded flat - optional
- Letters pre-assembled to rails to ensure fit.
- Larger letters shipped loose
- Unfinished backs - finished optional
- Flat 1/4" thick aluminum rails - standard, optional c-channel, painted or anodized, max. 95" long x 1/4", 1/2", 3/4", or 1" wide
- 10/24 or 1/4-20 stainless steel attachment screws.
- Min. 2 screws per letter, 3 screws (if possible) for letters 8" high or larger
- Metal rails are designed to be mounted to load bearing structures, holes and location to be determined by installer (rail mounting hardware & holes not included)
- Letters or logos, standard or custom



TITLE: FLAT CUT METAL - BOTTOM RAIL MOUNT			
MATERIAL: METAL		PRODUCT TYPE: FLAT CUT METAL	
DWG NO. FTMT60	REV 10/31/16	SCALE: AS INDICATED	SHEET 1 OF 1