

PRODUCT CONSTRUCTION EXAMPLE

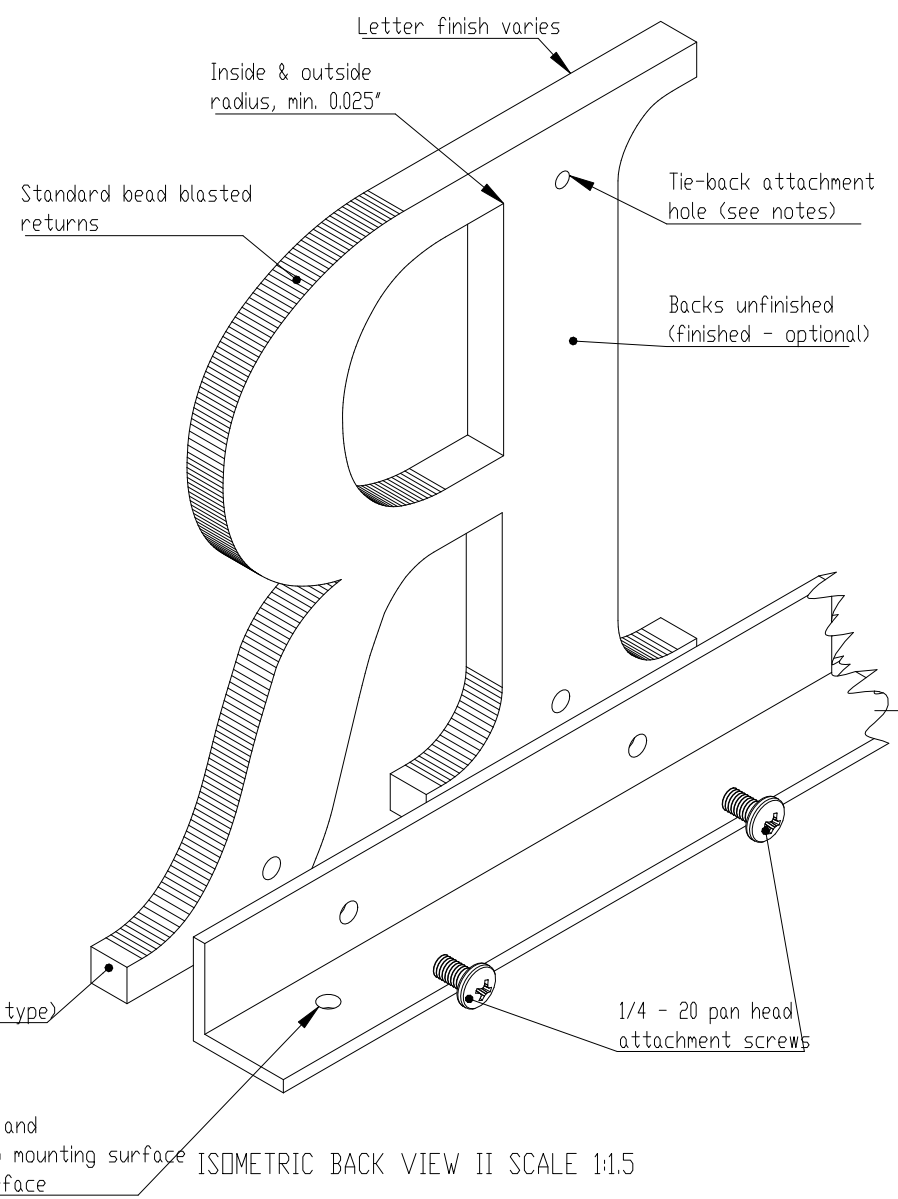
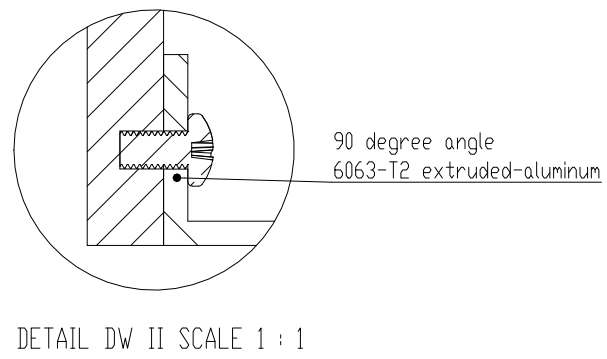
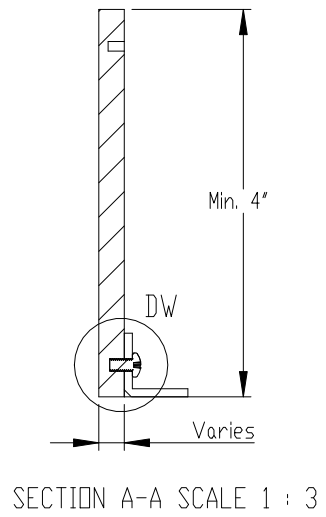
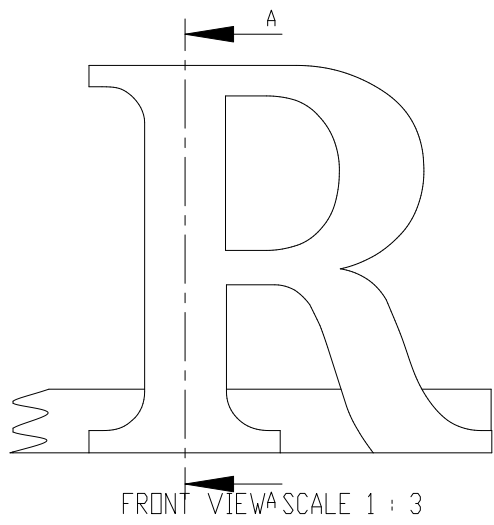

NOTES:

- Letters are pre-assembled to rails to ensure fit. Min. 2 screws per letter - Larger letters shipped loose
- Min. 4" - 24" high letters, min. 3/8" thick
- Optional rail lengths, up to 96", typically mounted by word
- Round letter bottoms - sanded flat- optional
- Multiple face finish options
- Rail finish: painted standard or custom color
- Min. 1/2" stroke letters
- Tie-backs recommended on letters over 12" high (not supplied)
- Optional angle bracket sizes: 2" x 2" x 1/4", 1 1/2" x 1 1/2" x 3/16", 1" x 1" x 3/16"
- Metal rails are designed to be mounted to load bearing structures, holes and location to be determined by installer (rail mounting hardware and holes not included)
- Letters or logos, standard or custom

Customer supplied hardware and holes - for mounting rail to mounting surface
Type varies by mounting surface



TITLE: FLAT CUT METAL - BOTTOM ANGLE BRACKET MOUNT			
MATERIAL: METAL		PRODUCT TYPE: FLAT CUT METAL	
DWG NO. FTMT80	REV 10/27/16	SCALE: AS INDICATED	SHEET 1 OF 1