

FRONT VIEW II SCALE 1 : 5

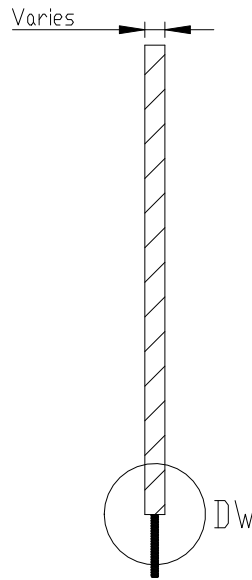

SECTION A-A SCALE 1 : 5

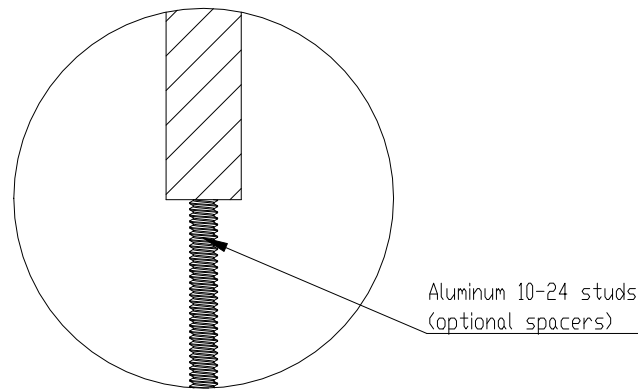

DETAIL DW SCALE 3 : 4

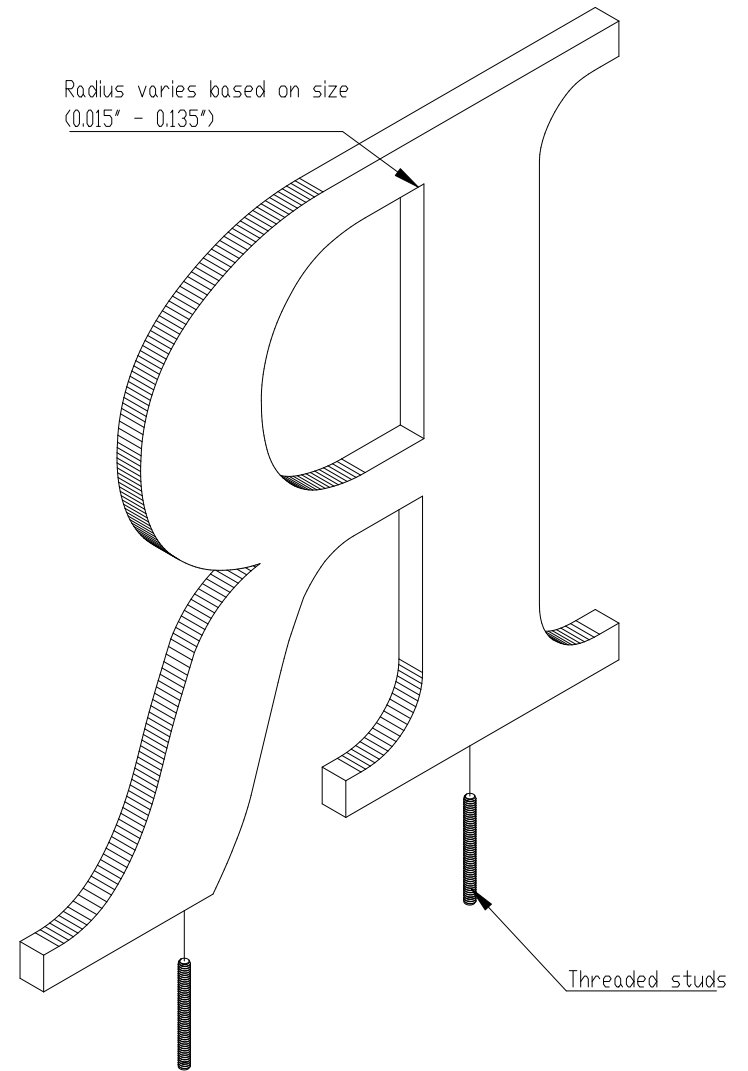

ISOMETRIC BACK VIEW II SCALE 1 : 3

NOTES:

- Min. 3/8" thick, drilled and tapped
- 2 studs per letter
- Optional sanded bottoms of round letters such as (C, D, U, G, etc...)
- Aluminum 10/24 studs (Stainless steel - optional)
- Available gauges (3/8", 1/2", 3/4", 1", 1 1/2" thick)
- Pigmented acrylic or sprayed with acrylic polyurethane paint
- Tie backs recommended on letters over 8" high (not supplied)
- Standard Gemini letter styles or per vector art



TITLE: LASER CUT ACRYLIC- DRILLTAP BOTTOM STUD MOUNT			
MATERIAL: IMPACT MODIFIED ACRYLIC		PRODUCT TYPE: PLASTIC LETTERS	
DWG NO. LASR150	REV. 1/29/2018	SCALE: AS INDICATED	SHEET 1 OF 1