

FRONT VIEW II SCALE 1:5

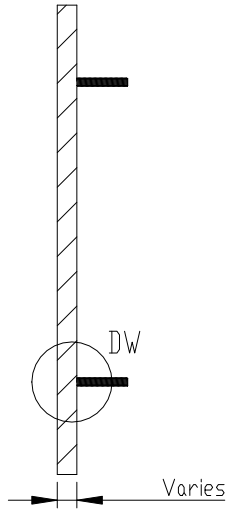

SECTION A-A II SCALE 1:5

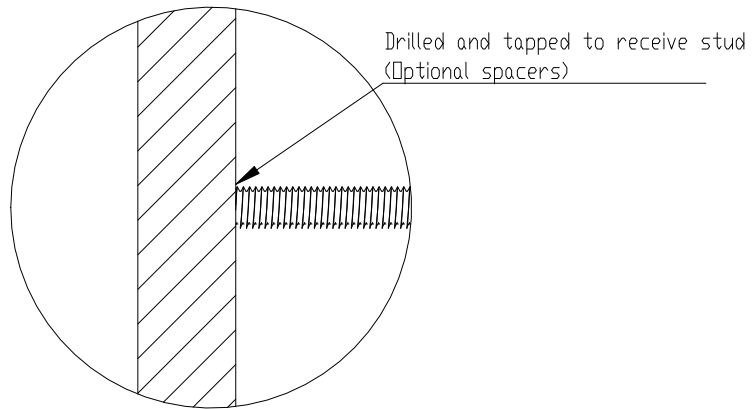

DETAIL DW II SCALE 1:1

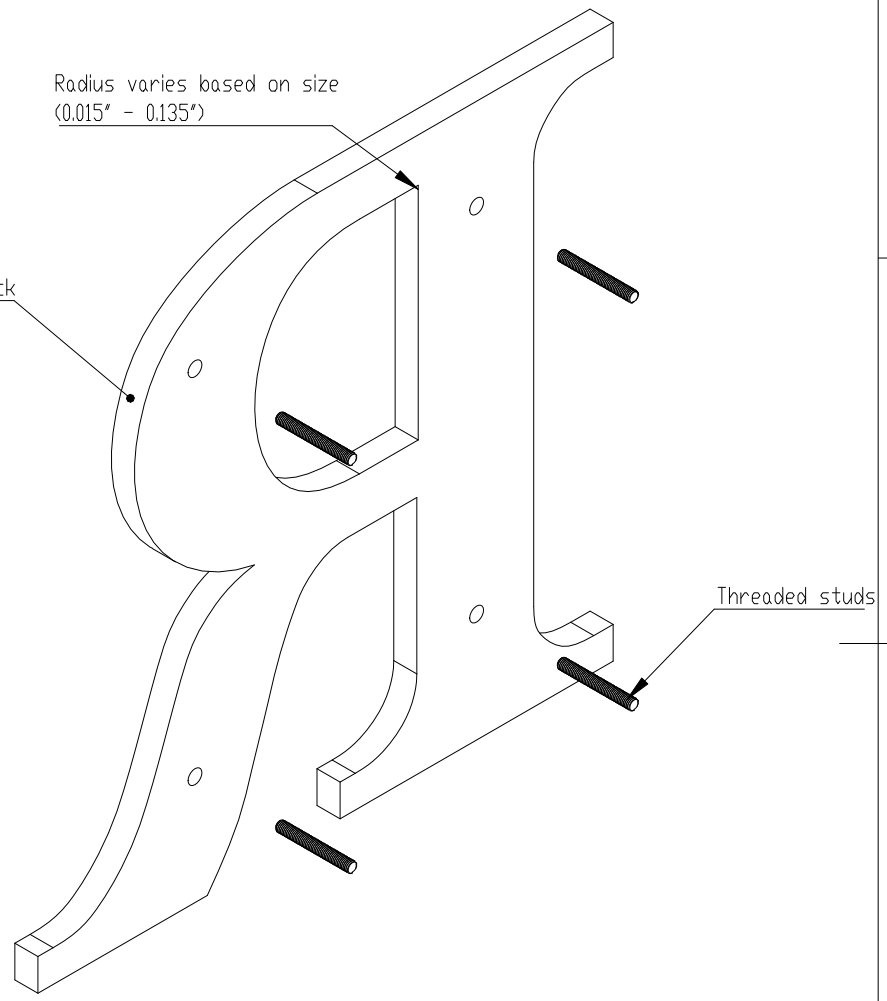

ISOMETRIC BACK VIEW II SCALE 1:3

NOTES:

- Pigmented or painted
- Impact modified acrylic - Laser cut
- Standard - backs are drilled and tapped for 10/24 aluminum studs
- Min. 3/8" thick- drilled and tapped
- Min. 1/4" stroke
- Aluminum 10/24 studs standard, 6/32 studs for thin strokes (stainless steel optional)
- Available gauges (3/8", 1/2", 3/4", 1", 1 1/2" thick)
- Pigmented acrylic or sprayed with acrylic polyurethane paint
- Standard Gemini letter styles or per vector art



TITLE: LASER CUT ACRYLIC - FLUSH STUD MOUNT			
MATERIAL: IMPACT MODIFIED ACRYLIC		PRODUCT TYPE: PLASTIC LETTERS	
DWG NO. LASR20	REV 09/15/16	SCALE: AS INDICATED	SHEET 1 OF 1