

NOTICE: ALL INTELLECTUAL PROPERTY (INCLUDING, WITHOUT LIMITATION, ALL COPYRIGHT AND DESIGN RIGHTS) AND PROPRIETARY RIGHTS TO ALL INFORMATION AND/OR TECHNICAL DATA CONTAINED ON THIS DRAWING BELONGS TO GUARDIAR USA, LLC. THE DRAWING MUST BE MAINTAINED BY YOU, THE RECIPIENT, IN STRICT CONFIDENCE. THIS DRAWING IS NOT TO BE DISCLOSED OR REPRODUCED, IN WHOLE OR IN PART, DIRECTLY OR INDIRECTLY, IN ANY MANNER WHATSOEVER, WITHOUT THE EXPRESS WRITTEN CONSENT OF GUARDIAR USA, LLC AND IT SHALL BE RETURNED UPON REQUEST.

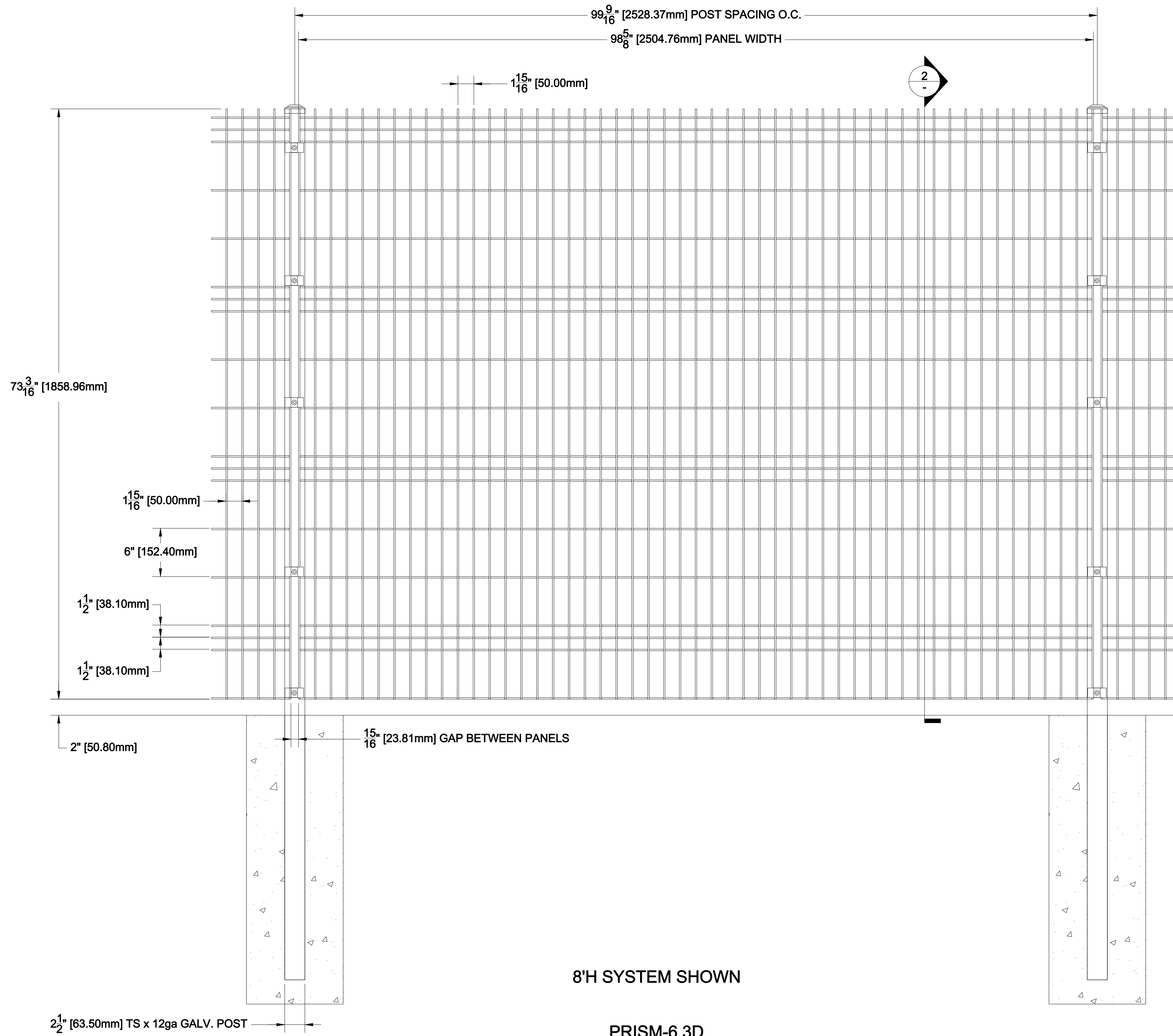

8'H SYSTEM SHOWN

1 PRISM-6 3D
TYPICAL ELEVATION
SCALE: NTS

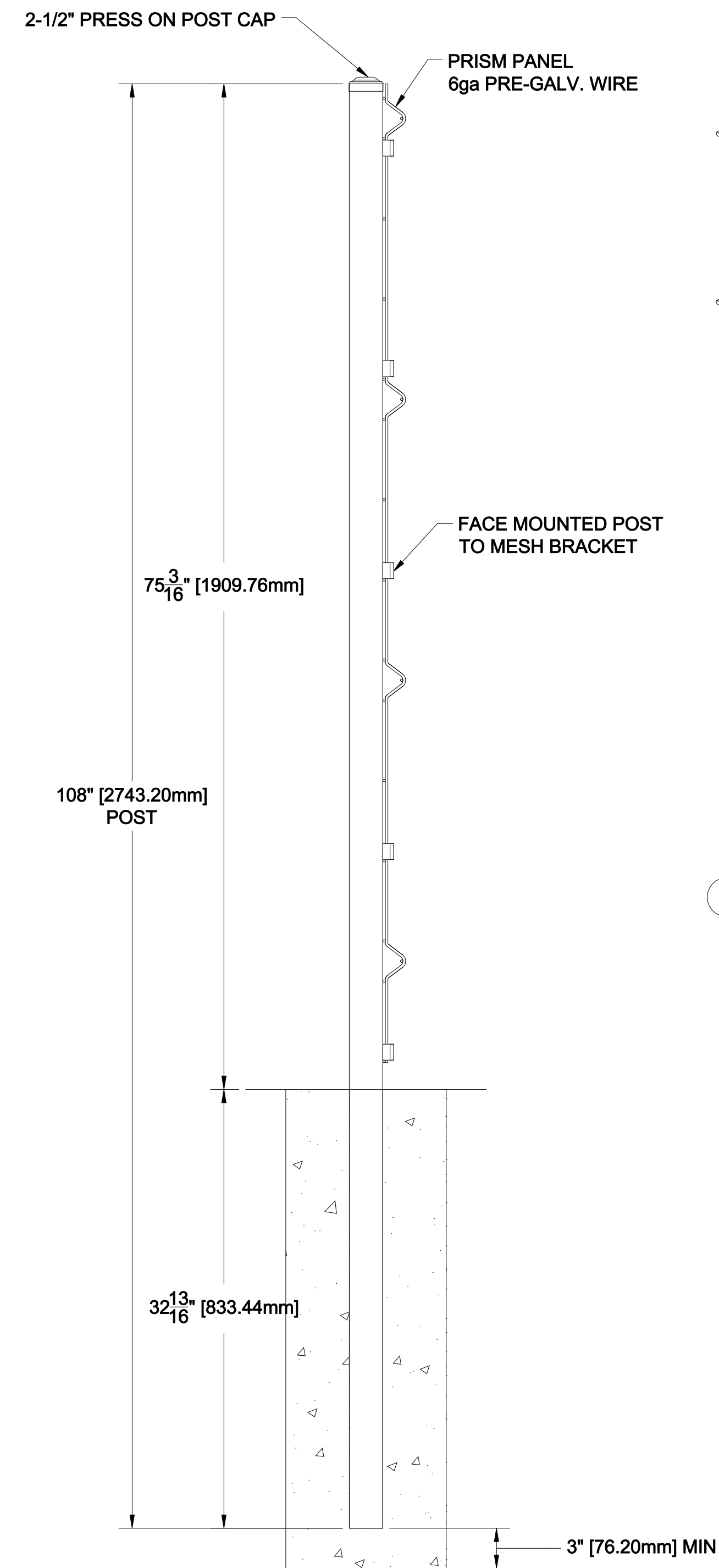

2 SECTION
SCALE: NTS

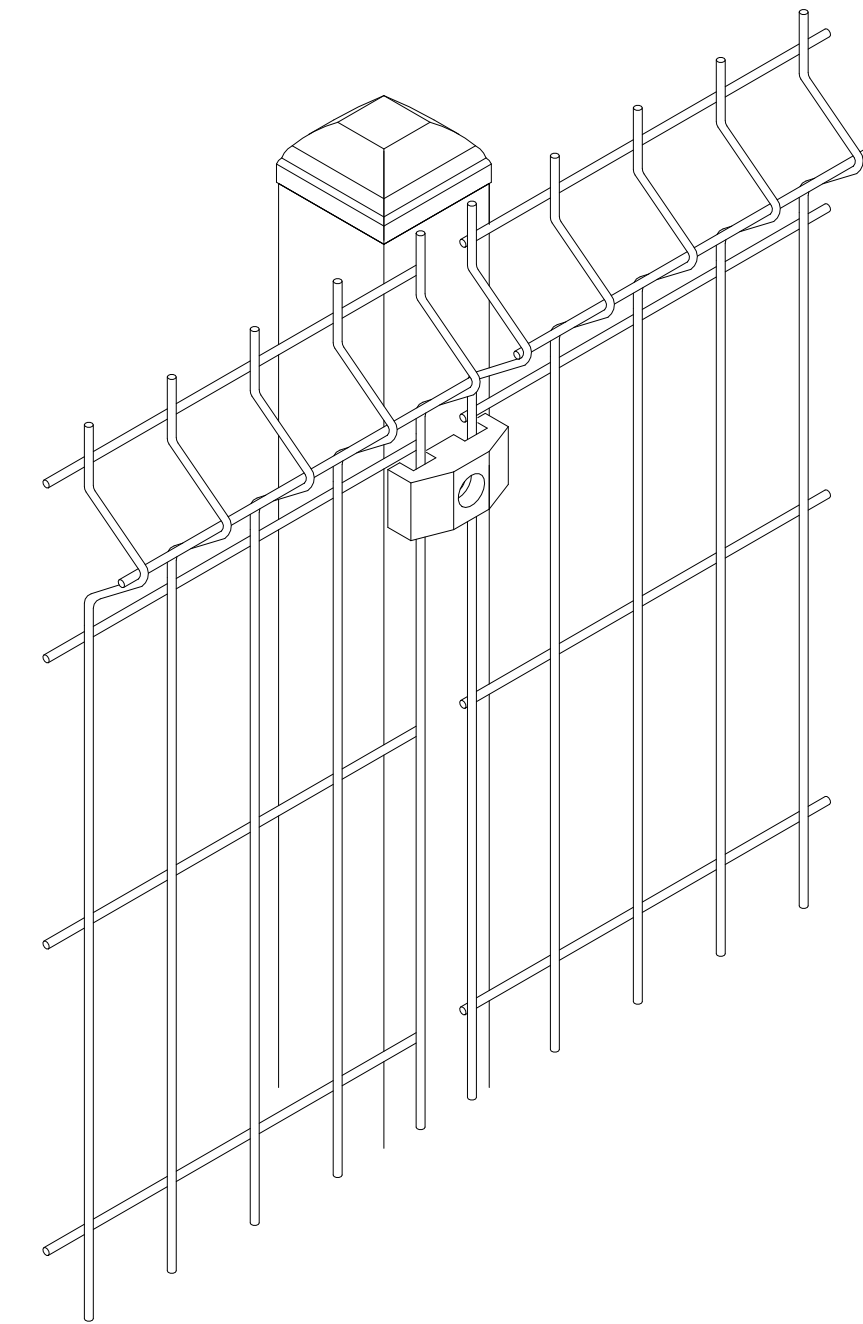

3 DETAIL AT POST
SCALE: NTS

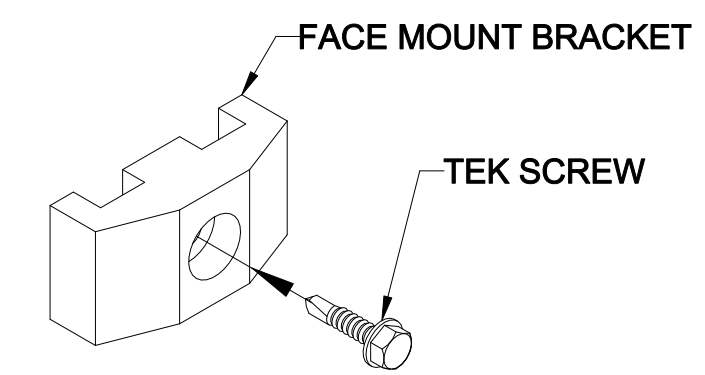

4 FACE MOUNT BRACKET
SCALE: NTS

Guardiar
Main: 972-878-7000 Fax: 214-887-4552
3309 S. I-45 ENNIS, TX 75119
www.Guardiar.com

REV	DATE	DESCRIPTION	BY

**PRISM-6 3D
TYPICAL ELEVATION**

MATERIAL SPECIFICATIONS
A36 STEEL: ALL PLATE, ANGLE & CHANNEL
A500 GRADE B: ALL TUBE STEEL
U.S.G.: ALL PRE-GALV. MTL.; A563 W/MIN.
ZINC COATING WEIGHT 0.80 OZ/FT²

FINISH
HDG OR POWDERCOATED

PROJECT	TYPICAL
CUSTOMER	CLIENT
QUOTE#	HS#
DATE	DRAFTER
14-DEC-18	REVIEWER
TJR	-

SHEET NO.
PR6 3D

DISCLAIMER: DRAWINGS MAY NOT INCLUDE FULL PRODUCT DETAILS AND CAN CHANGE WITHOUT NOTICE.