

HINGE DETAIL

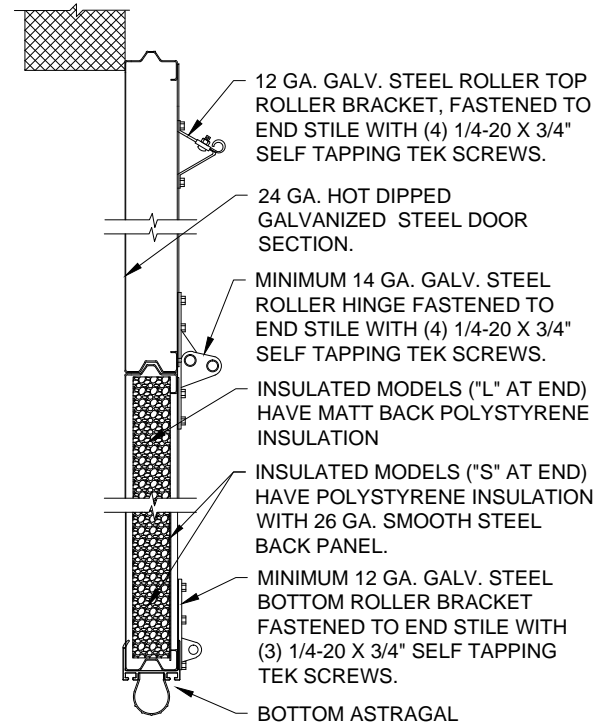

SIDE ELEVATION OF DOOR

ADDITIONAL NOTES:

AVAILABLE SECTION HEIGHTS ARE 21" AND 24". NOMINAL THICKNESS OF SECTION WITH END STILES TO BE 2". STEEL SKINS TO BE PRE-PAINTED WITH A URETHANE PRIMER BASE COAT AND A BAKED-ON POLYESTER TOP COAT. INTERIOR COLOR IS WHITE. INSULATED MODELS WITH AN "L" AT THE END HAVE MATT BACK POLYSTYRENE FOAM AND MODELS WITH AN "S" AT THE END HAVE POLYSTYRENE FOAM WITH 26 GAUGE SMOOTH STEEL BACK PANEL, BOTH PROVIDING A U-VALUE OF 0.135 (R-VALUE OF 7.45).

MODEL NUMBER

C2415/C2415L/C2415S

320 Sycamore St.
Wauseon, Ohio 43567
© Copyright 2017

