

#70 BOTTOM CASTER

For 510, 550 & 560 SLIDER SYSTEMS

MAXIMUM PANEL WEIGHT: 181 Kg (400 lbs.)

Top guide pins must align with caster for stacking.

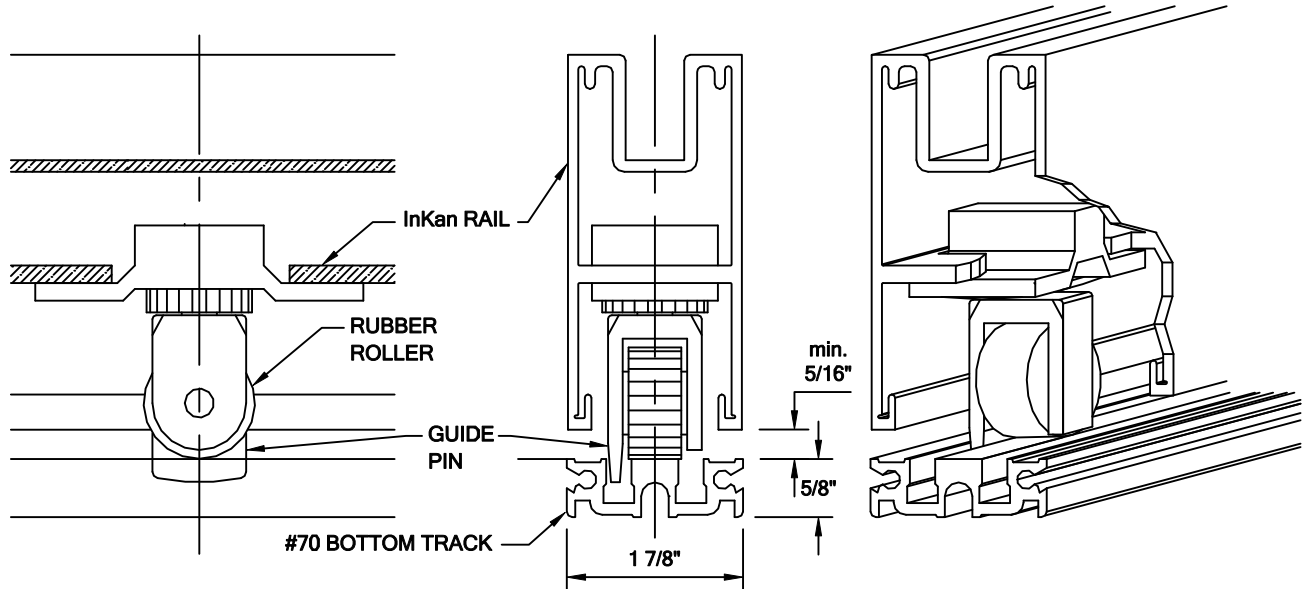

TANDEM ROLLER

For 510 SERIES SYSTEMS

MAXIMUM PANEL WEIGHT: 113 Kg (250 lbs)

ROLLER LOCATED 2 1/2" from RAIL ENDCAP.

Adjustment screw accessed by removing endcap

