

PARALLEL STACKING UNIT

For 550 SLIDER SYSTEM

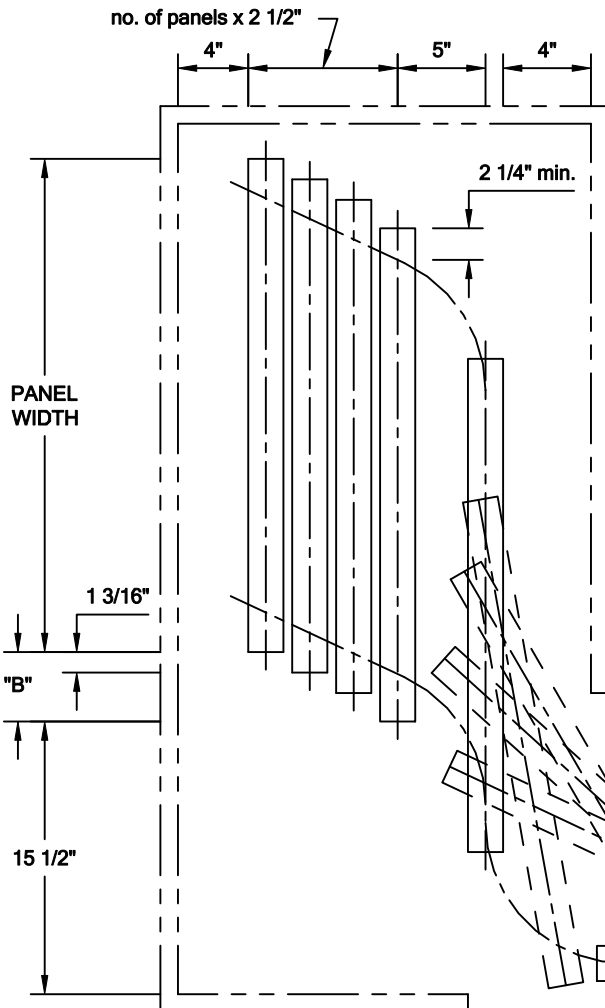
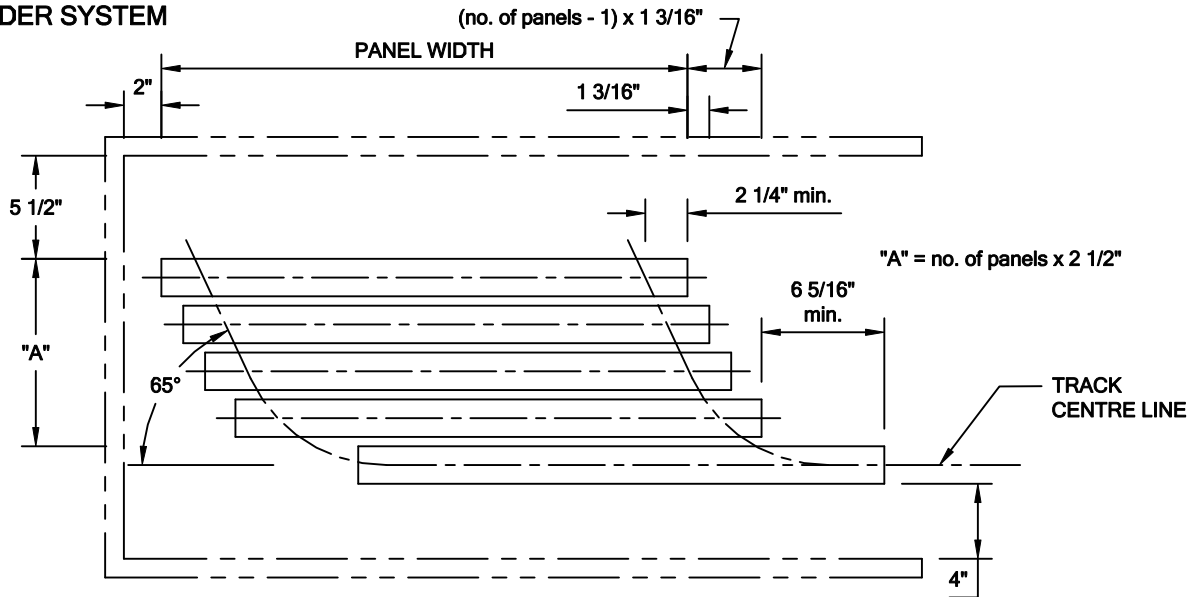

90° STACKING UNIT

For 560 SLIDER SYSTEM

"B" = (no. of panels - 1) x 1 3/16"