

PLAN

	14 WHEEL LAKE BRAPTON ONTARIO, CANADA, L4T 3T2	PROJECT NAME GLASS BALUSTRADE AND GLASS TREAD
	PHONE# (416) 753-8347 FAX# (416) 753-8347	DATE 28 JULY 2014
		PROJECT NO. 1

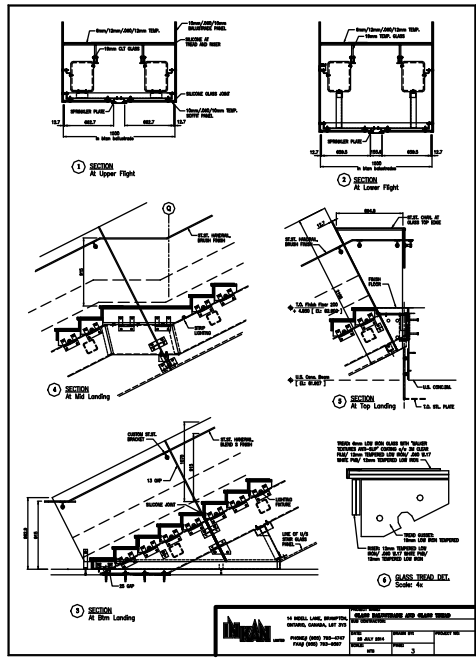

14 WHEEL LAKE BRAPTON ONTARIO, CANADA, L4T 3T2	PROJECT NAME GLASS BALUSTRADE AND GLASS TREAD
PHONE# (416) 753-8347 FAX# (416) 753-8347	DATE 28 JULY 2014
	DRAWN BY MTS
	PROJECT NO. 1

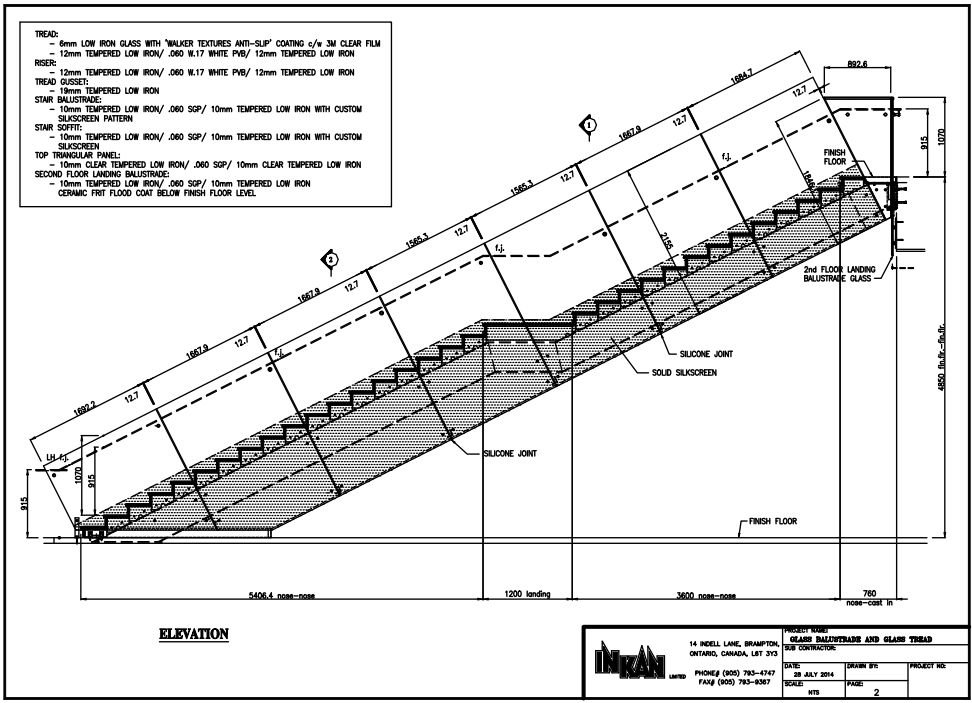

ELEVATION

	14 WHEEL LAKE BRAPTON ONTARIO, CANADA, L4T 3T2	PROJECT NAME GLASS BALUSTRADE AND GLASS TREAD
	PHONE# (416) 753-8347 FAX# (416) 753-8347	DATE 28 JULY 2014
		PROJECT NO. 1