

Door - Load Bearing Back to Back Header Back to Back Jamb

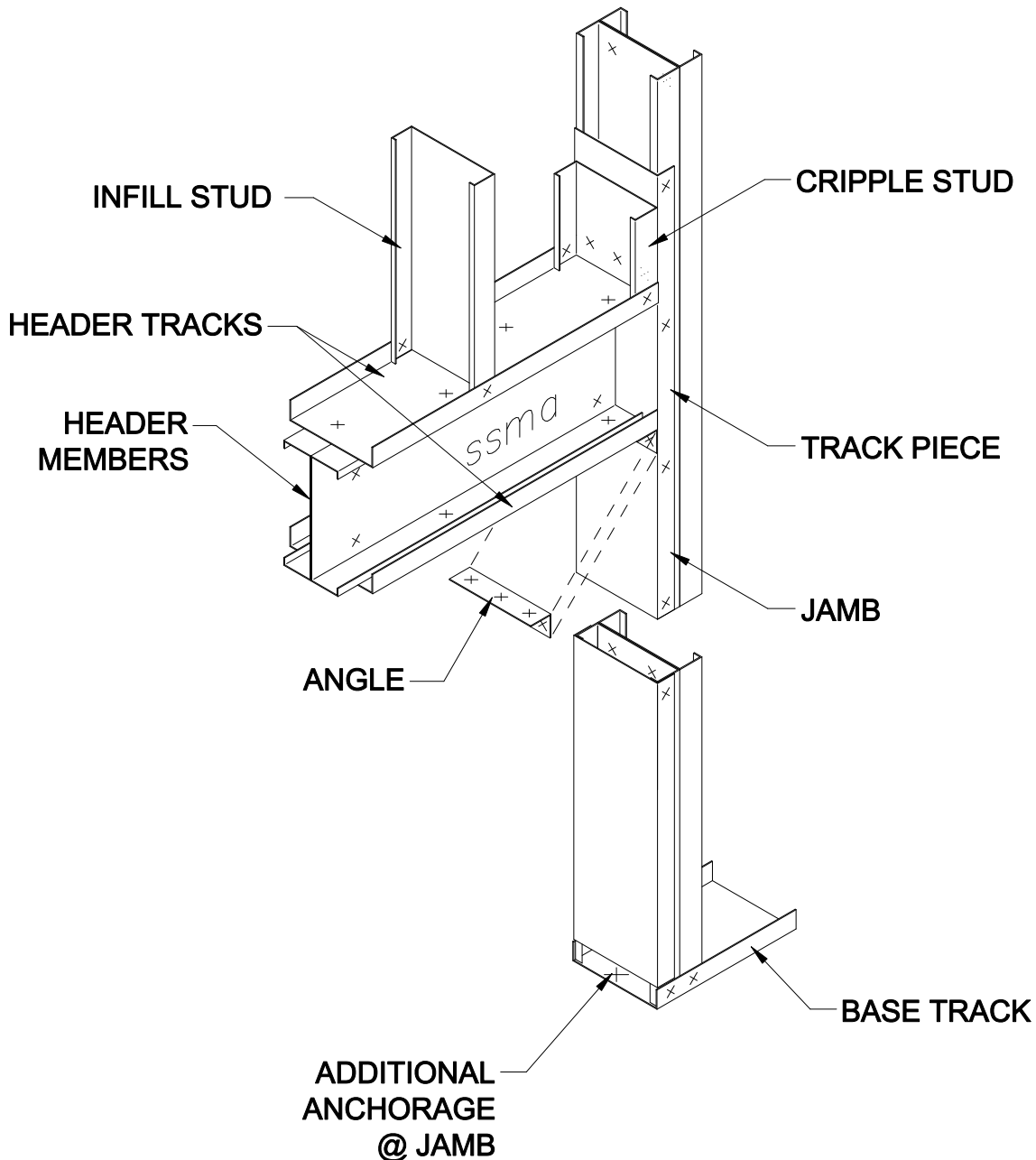

ADVANTAGES:

1. Use of cripple stud to receive head/sill tracks at the jamb studs helps maintain alignment of finishes.
2. Back to back header reduces web-crippling reinforcement requirements.
3. Using a back to back jamb with a track cap piece at the opening eliminates welding so that thinner material can be used depending on the load requirements.
4. Reduces the need to reinforce the web at the end reactions of the jamb studs.
5. Provides better load transfer from jamb stud to base track vs. single jamb stud.

DISADVANTAGES:

1. Requires the clip angle below the head track to be sized to transfer the vertical load from the head into the jamb.
2. Back to back headers will not provide backing for attaching window covering support.
3. Material build-up at the jamb studs can cause finish and window frame problems.