

# Door - Load Bearing Single Header with Strongback Single Jamb

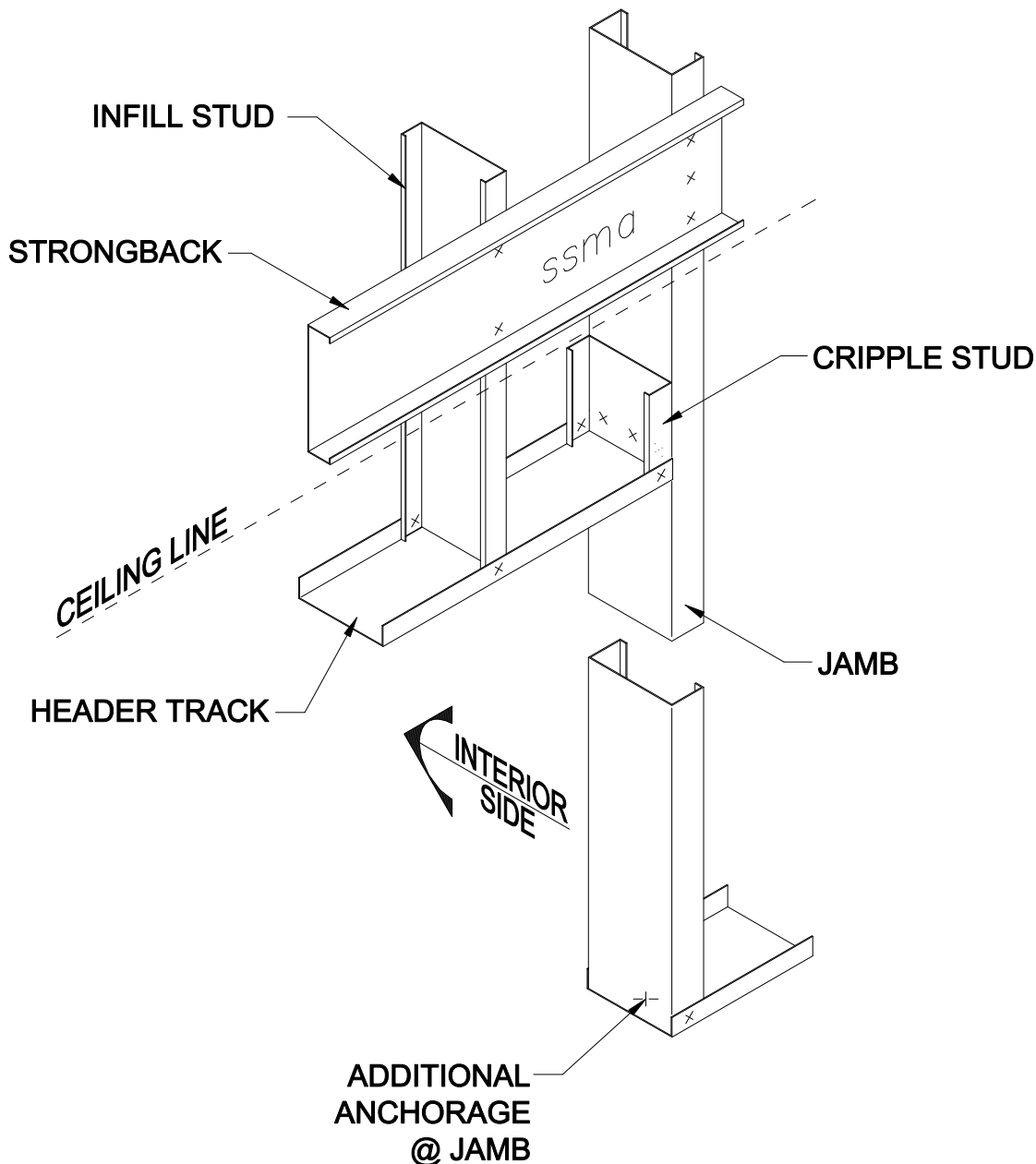

## ADVANTAGES:

1. Use of cripple stud to receive head/sill tracks at jamb studs helps maintain alignment of finishes.
2. Strongback header minimizes number of members to be installed vs. back to back or boxed header.
3. Using a wider flange and thicker jamb stud material reduces cost of installation compared to built-up jamb studs.
4. Using a wider flange reduces possibility of installing a wall stud as a jamb stud.
5. Provides good vertical load transfer at each strongback header into jamb stud.
6. Reduces web-crippling reinforcement being required at end of strongback header.

## DISADVANTAGES:

1. Requires a ceiling being installed to hide vertical strongback.
2. Strongback would interfere with installing interior wall covering at the strongback.
3. May require a thicker or wider flange head track member with only one member being installed to resist the horizontal load from the opening.
4. Base track may require reinforcement with clip angle and direct attachment to transfer end reaction from jamb stud.