

# Door - Load Bearing Single Header with Strongback Boxed Jamb

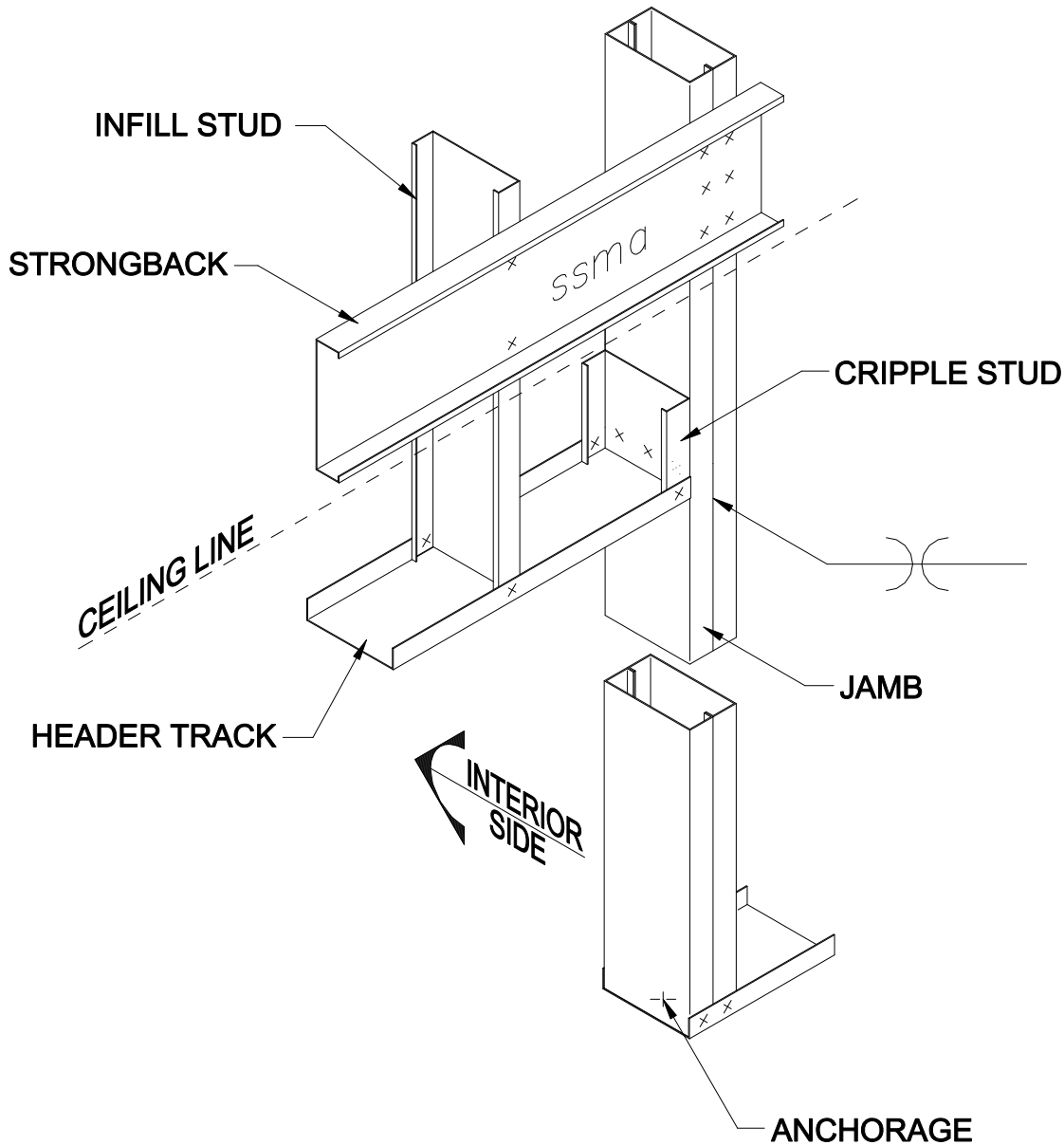

## ADVANTAGES:

1. Use of cripple stud to receive head/sill tracks at jamb studs helps maintain alignment of finishes.
2. Strongback header minimizes number of members to be installed vs. back to back or boxed header.
3. Boxed jamb studs welded together reduces material build-up and finish problems.
4. Provides good vertical load transfer at each strongback header into jamb stud.
5. Reduces web-crippling reinforcement being required at end of strongback header.
6. Provides better load transfer from jamb stud to base track vs. single jamb stud.

## DISADVANTAGES:

1. Requires a ceiling being installed to hide vertical strongback.
2. Strongback would interfere with installing interior wall covering at the strongback.
3. High-end reactions for single web jamb studs may require reinforcement to reduce web-crippling failure.
4. May require a thicker or wider flange head track member with only one member being installed to resist the horizontal load from the opening.
5. Requires 43 mil and thicker jamb stud material so weld can be made easily.