

Door - Load Bearing Single Header with Strongback Back to Back Jamb

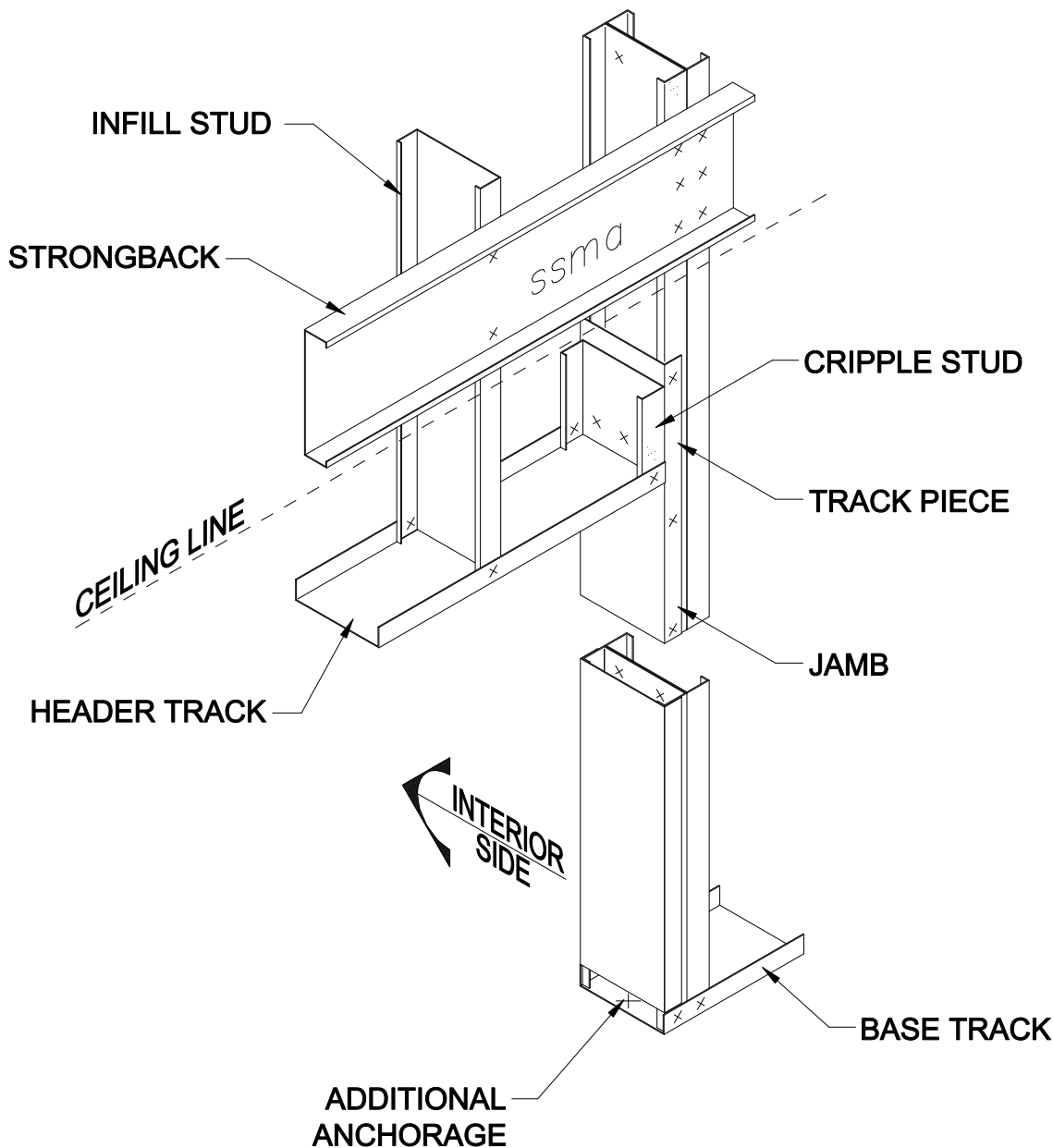

ADVANTAGES:

1. Use of cripple stud to receive head/sill tracks at jamb studs helps maintain alignment of finishes.
2. Strongback header minimizes number of members to be installed vs. back to back or boxed header.
3. Using a back to back jamb with a track cap piece at the opening eliminates welding so that thinner material can be used depending on the load requirements.
4. Reduces the need to reinforce the web at the end reactions of the jamb studs.
5. Provides good vertical load transfer at each strongback header into jamb stud.
6. Reduces web-crippling reinforcement being required at end of strongback header.
7. Provides better load transfer from jamb stud to base track vs. single jamb stud.

DISADVANTAGES:

1. Requires a ceiling being installed to hide vertical strongback.
2. Strongback would interfere with installing interior wall covering at the strongback.
3. Material build-up at the jamb studs can cause finish and window frame problems.
4. May require a thicker or wider flange head track member with only one member being installed to resist the horizontal load from the opening.