

END CAP DETAIL

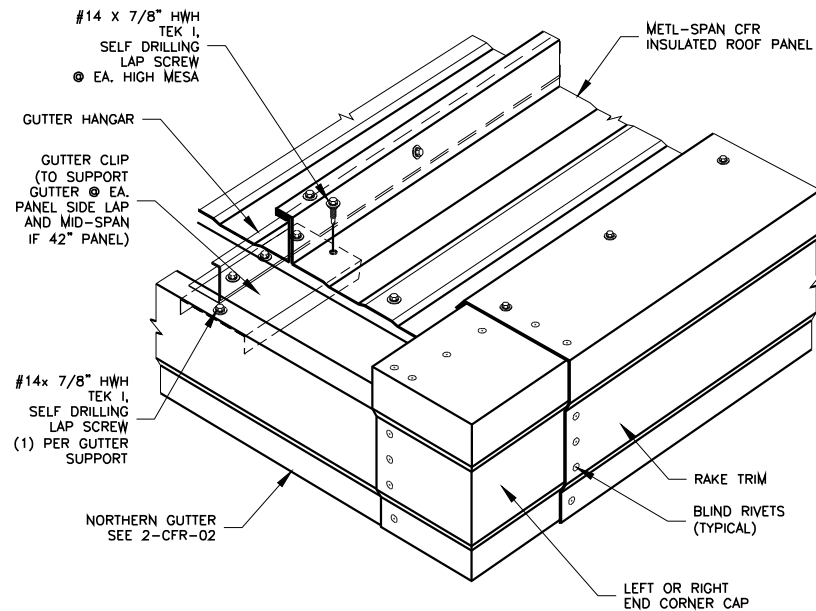

CORNER CAP DETAIL

ROOF THICKNESS TR	GUTTER END CAP	GUTTER CORNER BOX RIGHT	GUTTER CORNER BOX LEFT
2"	F3933	F5204-R	F5204-L
2.5"	F3933	F5204-R	F5204-L
3"	F3933	F5204-R	F5204-L
4"	F4232	F5205-R	F5205-L
5"	F4232	F5205-R	F5205-L
6"	F4234	F5203-R	F5203-L

COMMERCIAL AND INDUSTRIAL

CFR CORNER AND END-CAP DETAIL WITH NORTHERN GUTTER

2-CFR-13
DATE: Nov. 9, 2016