

DIMENSIONS IN () =
MILLIMETERS

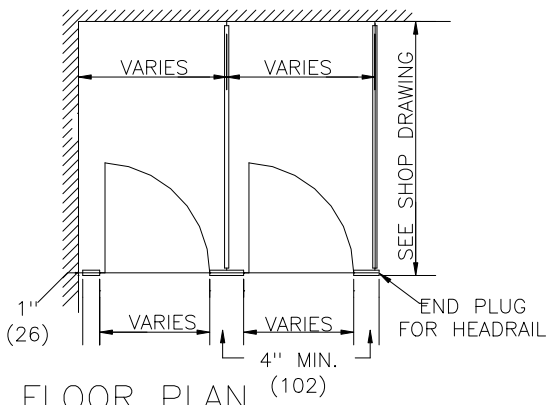

FLOOR PLAN

(DOTTED LINES INDICATE HEADRAIL)

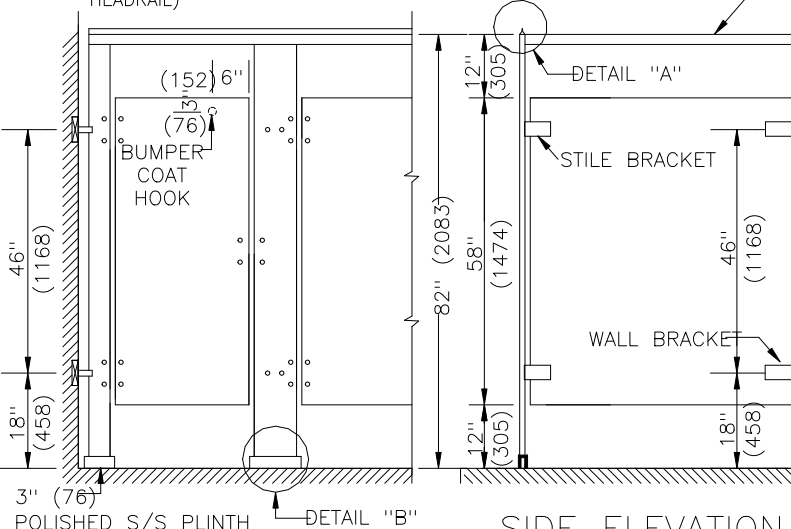

SIDE ELEVATION

FRONT ELEVATION

#12 X 2 1/2" (64)
S.M.S FASTENER AND RAWL PLUG

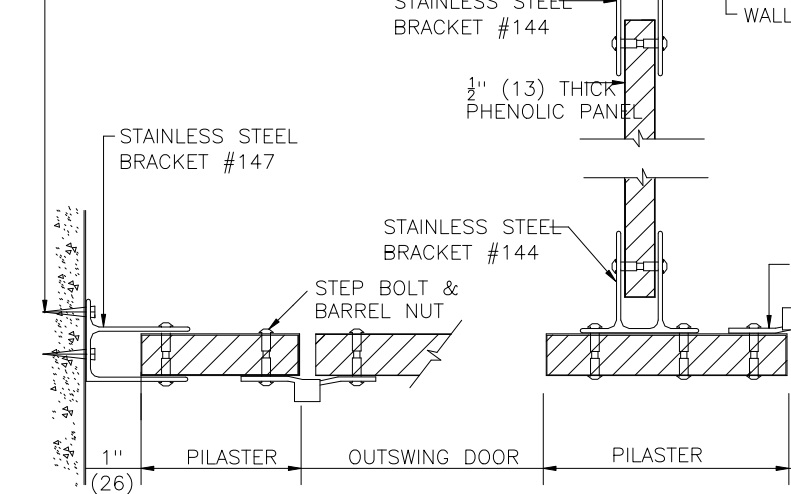

DETAIL B

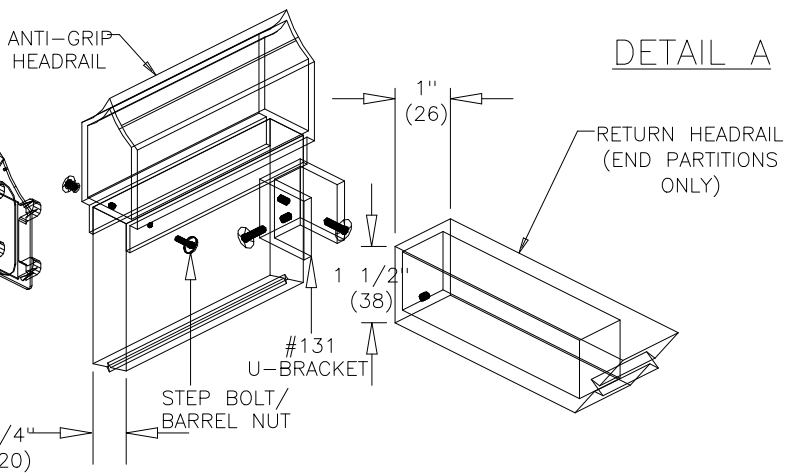
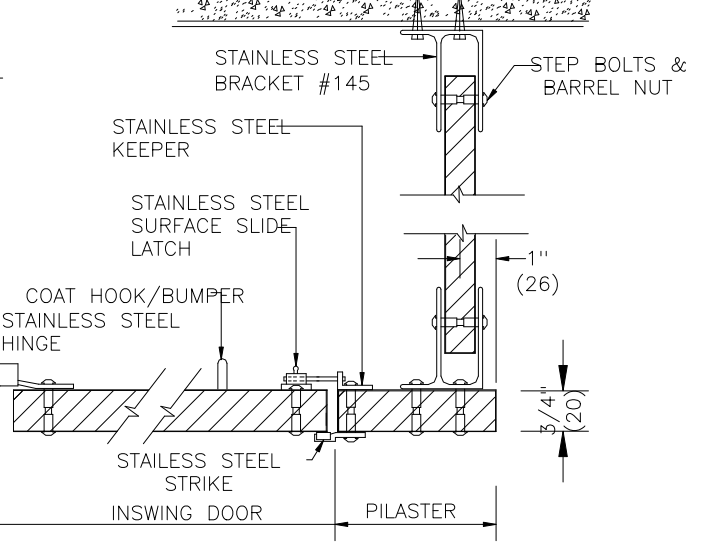

DETAIL A

NOTES: This drawing is a standard detail intended to show general information. See shop drawings for actual job layout and specific job conditions (that supersede any blocking (by others) shown for standard CPZ stir-up brackets. For full height or any other bracket, consult with Metpar distributors for blocking information and loadings.



METPAR CORP

SOLID PHENOLIC

95 State Street, Westbury, NY 11590

STANDARD DETAIL FP-500

THE CORINTHIAN

Tel: 516-333-2600 Fax: 516-333-2618

FP500PH.DWG

05/27/2005