

DIMENSIONS IN () =
MILLIMETERS

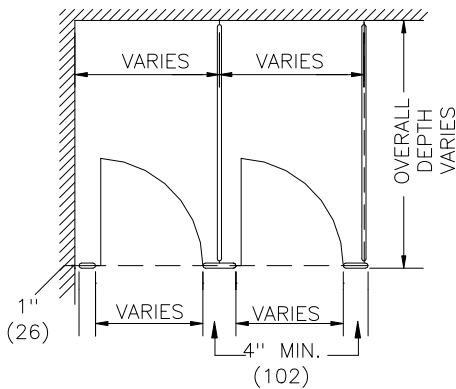

FLOOR PLAN

(DOTTED LINES INDICATE HEADRAIL)

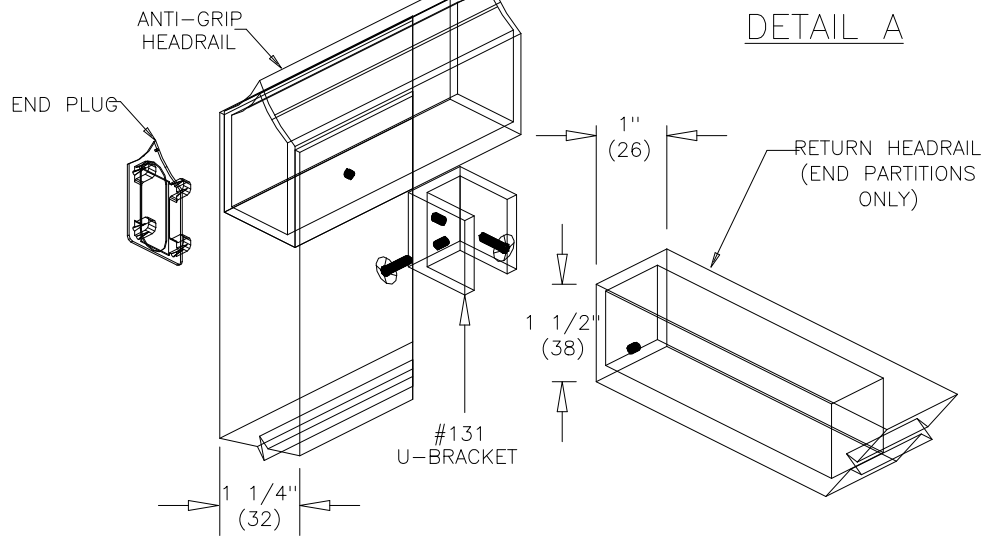

DETAIL A

NOTES: This drawing is a standard detail intended to show general information. See shop drawings for actual job layout and specific job conditions (that supersede any blocking (by others) shown for standard CPZ stir-up brackets. For full height or any other bracket, consult with Metpar distributors for blocking information and locations.

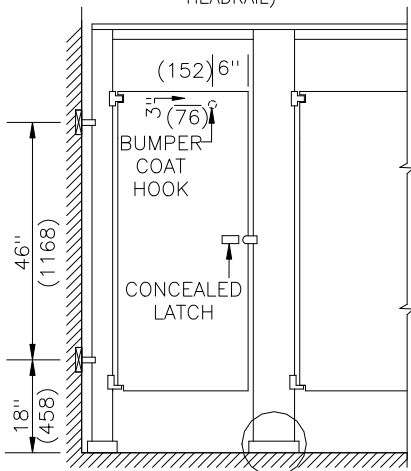

FRONT ELEVATION

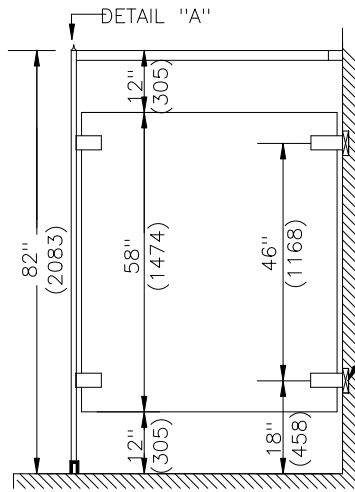

SIDE ELEVATION

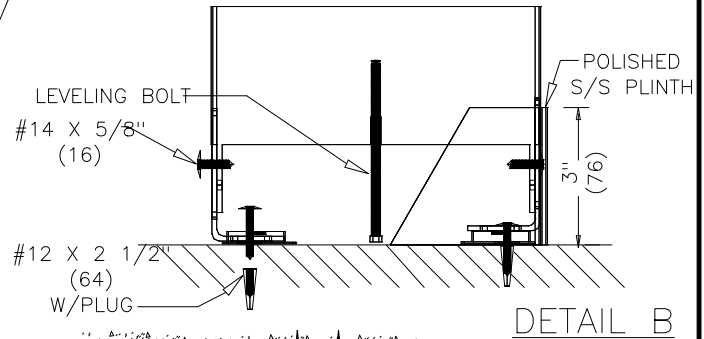

DETAIL B

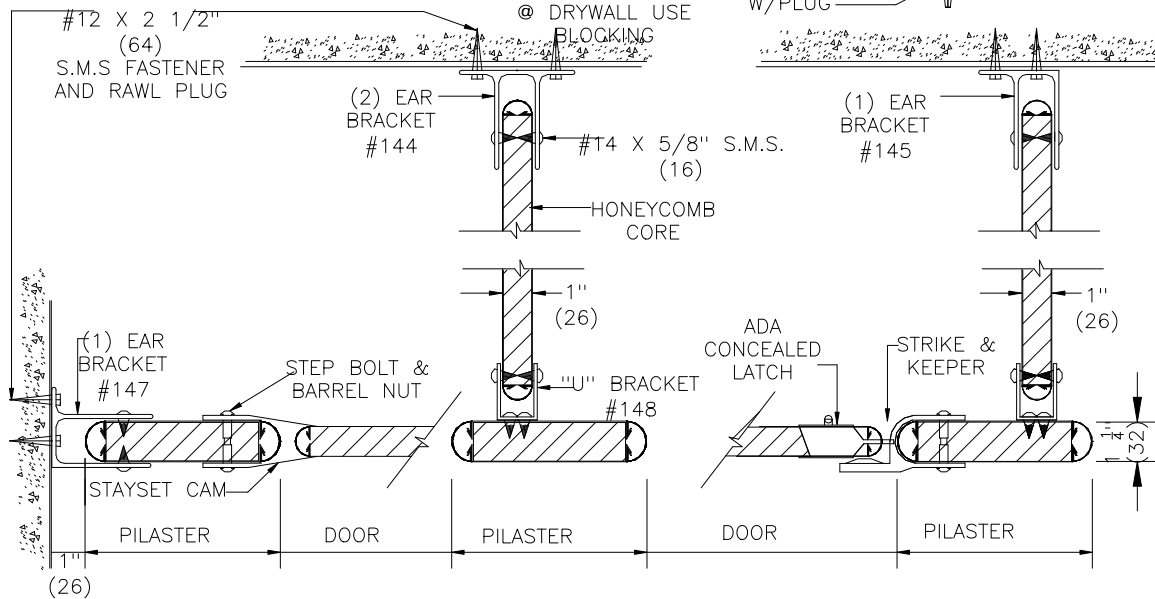

METPAR
95 State Street, Westbury,
Tel: 516-333-1800 Fax:
www.Metpar.com
Sales@Metpar.com

STAINLESS STEEL
Standard Typical Detail -
FP500

FP500SS.DWG The Corinthian 05/04/2009