

Notes: Detail may vary depending on type of tile being used. Two-piece tile method may replace requirement for metal flashing.

METAL CAP CONDITION

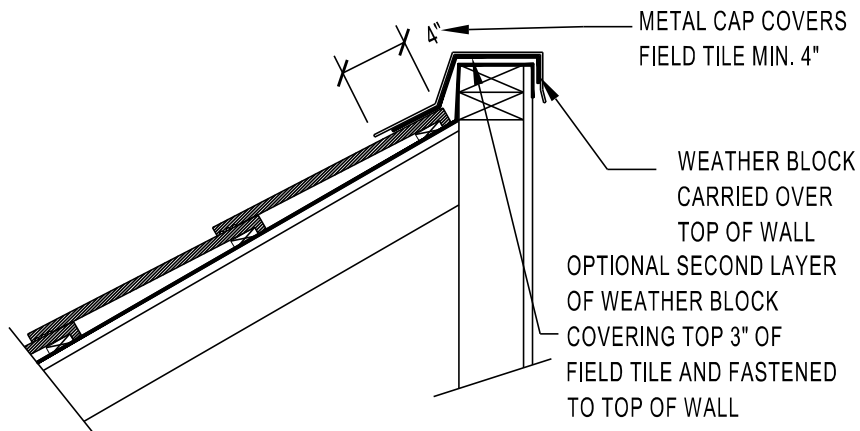

Notes:

1. For recommended underlayment and fastening requirement, see Table 1A and 1B.
2. Dimension shown are minimums and are intended to be approximate to allow for reasonable tolerance due to field conditions, and area practices.

