

(Where Required)

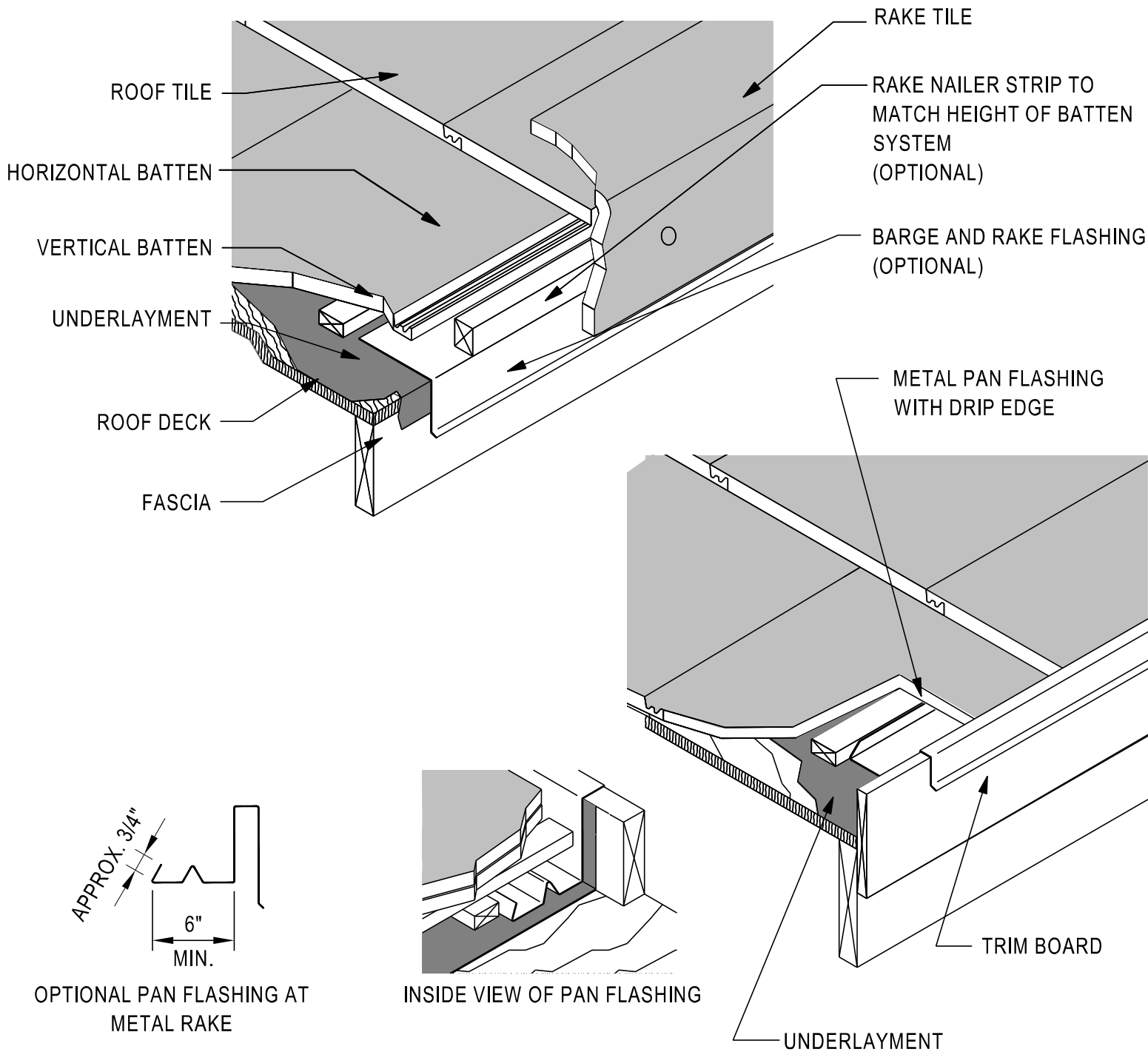

Notes:

1. For recommended underlayment and fastening requirement, see Table 1A and 1B.
2. Sheet metal Flashing shall be a minimum of (No. 26 galvanized sheet gauge) not less than 0.019 inch corrosion-resistant metal (G90). See Table A for additional options.
3. Dimensions shown are minimums and are intended to be approximate to allow for reasonable tolerances due to field conditions, and local area practice.
4. Rake flashing and wood nailer/trim board shall be raised above the roof deck to a height greater than the height of the installed roof tile.
5. Rake tiles must be fastened into a minimum 2" nominal gable fascia board, gable trim, or equivalent in dimension from multiple pieces.

