

SURFACE COATING SPEC.	
Description	
BARE (See material description)	
STONE COATED*	
PAINTED (COLOR)	
a) 0.7 mil - 0.8 mil POLYESTER	
PRIMER	
a) 0.2 mil - 0.4 mil POLYESTER	

SAP#	Description	Surface A	Surface B
-	Top Row Barrel Vault	Stone Coated	Bare

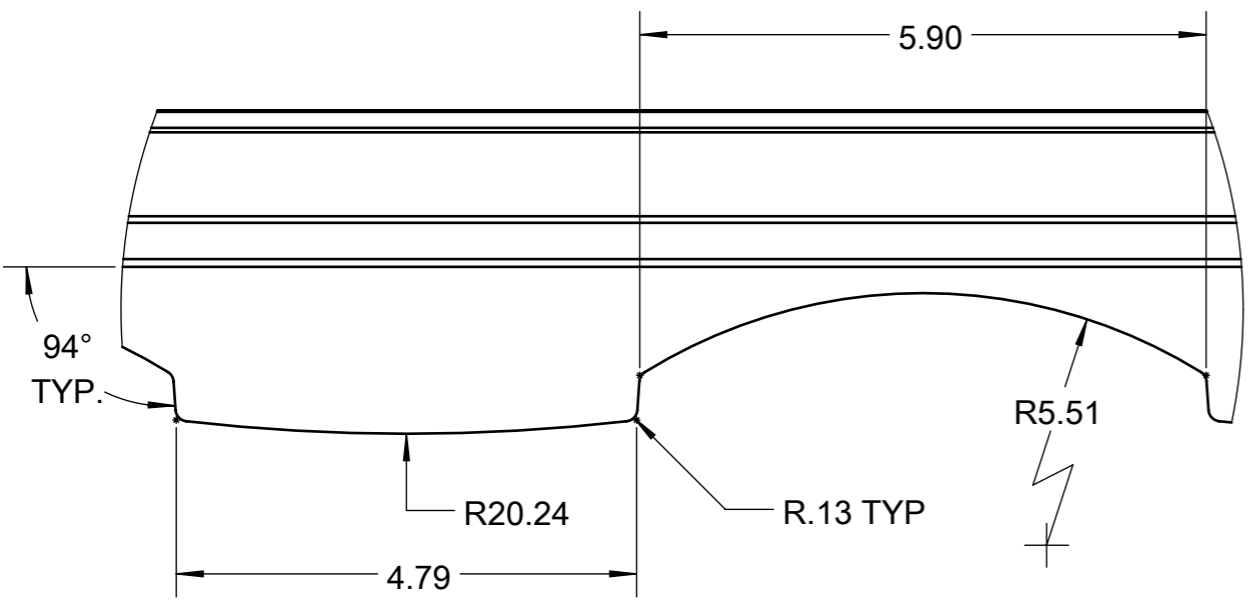

DETAIL A  
SCALE 1 : 2

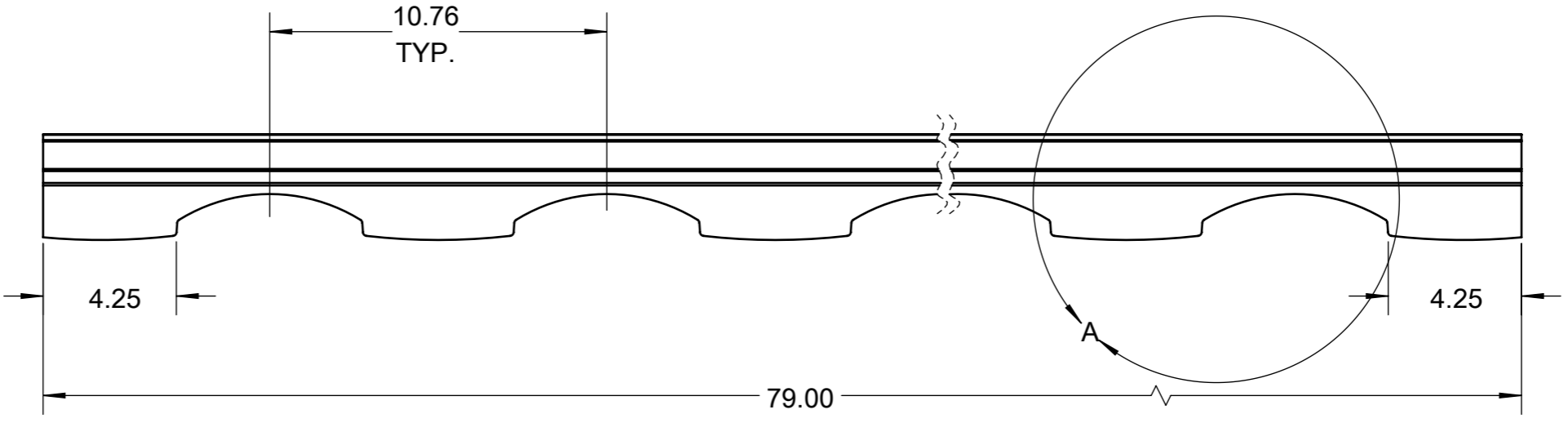
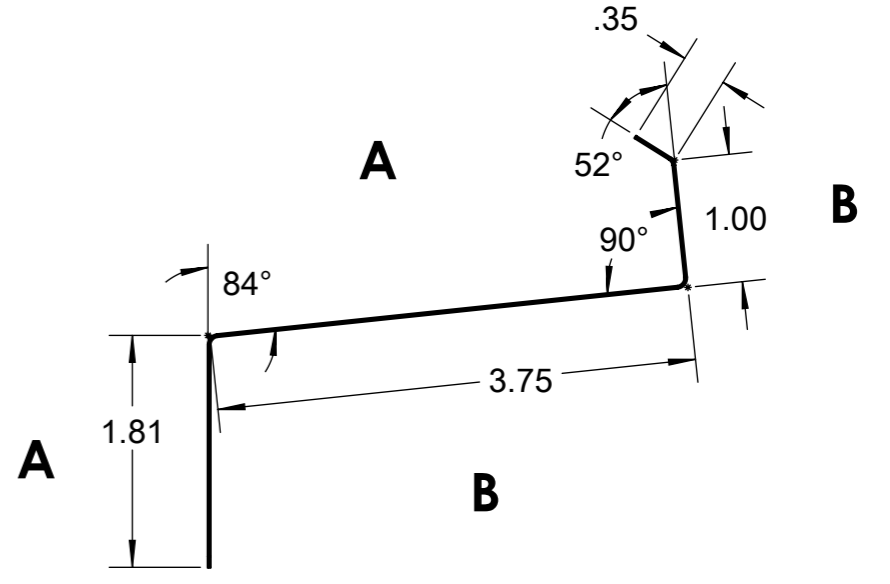

NOTE: MATERIAL SIZE, FLAT STOCK: W X L= 6 15/16" X 79"  
 BOTH SIDE COIL COATING: 0.2 mil ± 0.005 mil CLEAR OR TINTED WATER BASED ACRYLIC

\* STONE COATING SHALL BE APPLIED TO BARE FORMED PART BY BORAL ROOFING.

REFERENCE:  
 APPROX WEIGHT: 2.61 lb

REVISIONS					MATERIAL: 0.0170"± 0.0005" THICKNESS, ASTM A792, AZ50, (40 ksi Min)	UNLESS OTHERWISE SPECIFIED TOLERANCES ARE: SURFACE FINISH: SEE DRAWING TOLERANCES: ±.0625" ANGULAR: ±3°	SAP#		
ZONE	REV.	DESCRIPTION	DATE	APPROVED			TITLE	UNIT: INCH	
						DRAWN S. Barry CHECKED J. Haniff APPROVED C. Falatoon ASSY. DRAWING	DATE 10/31/2018	SHEET 1 OF 1	REV A
							DATE 1/2/2019	DATE 09/20/2019	DRAWING NUMBER
					SCALE 1:10 UNLESS NOTED		PT-0634		

COPYRIGHT © 2010 BORAL ROOFING  
This drawing is the property of BORAL ROOFING and is subject to return upon demand. It is submitted for the confidential use of the borrower and only in connection with proposals or contracts of this organization upon the expressed condition that it is not to be reproduced, copied, sent or otherwise disposed of directly or used directly or indirectly in any way detrimental to BORAL ROOFING and its subsidiaries.