

NOTE:

FAB AND DEBURR BEFORE ANODIZING

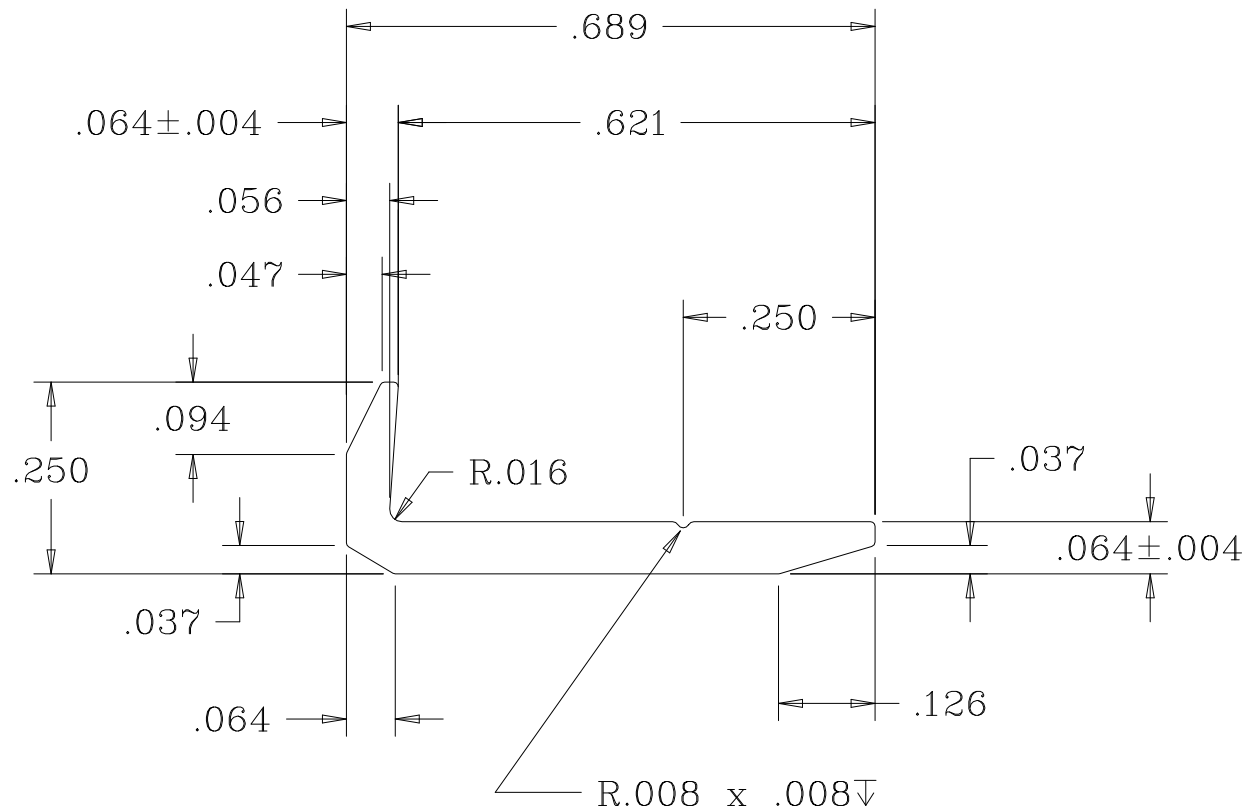
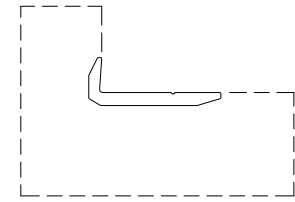

MiMORSE
INDUSTRIES
Working Solutions in Aluminum, Plastics and Stainless Steel

DR BY: ADAM FINCH 2/09/04
CUT LENGTH: (144") 12' +/- .063"

PART NUMBER: A50-0273
DESCRIPTION:

FINISH:
AREA: 0.0563 INCH² WPF: 0.066 LB

UNSPECIFIED CORNERS: 0.010
ALLOY: 6463-T5 WALL: 0.064

±1/64	FRACTION X.X X.XX X.XXX X.XXXX
±0.1600	
±0.0160	
±0.0005	
SUBTRACT 5 PTS. FOR EACH UNIT OF TOL. ANGLE ±1°	

Telephone: (253) 852-1399
Fax: (253) 520-9972
www.morseindustries.com