

NOTES:

- 1) ALL RADII ARE 0.010" UNLESS NOTED
- 2) WALL THICKNESS IS 0.025"

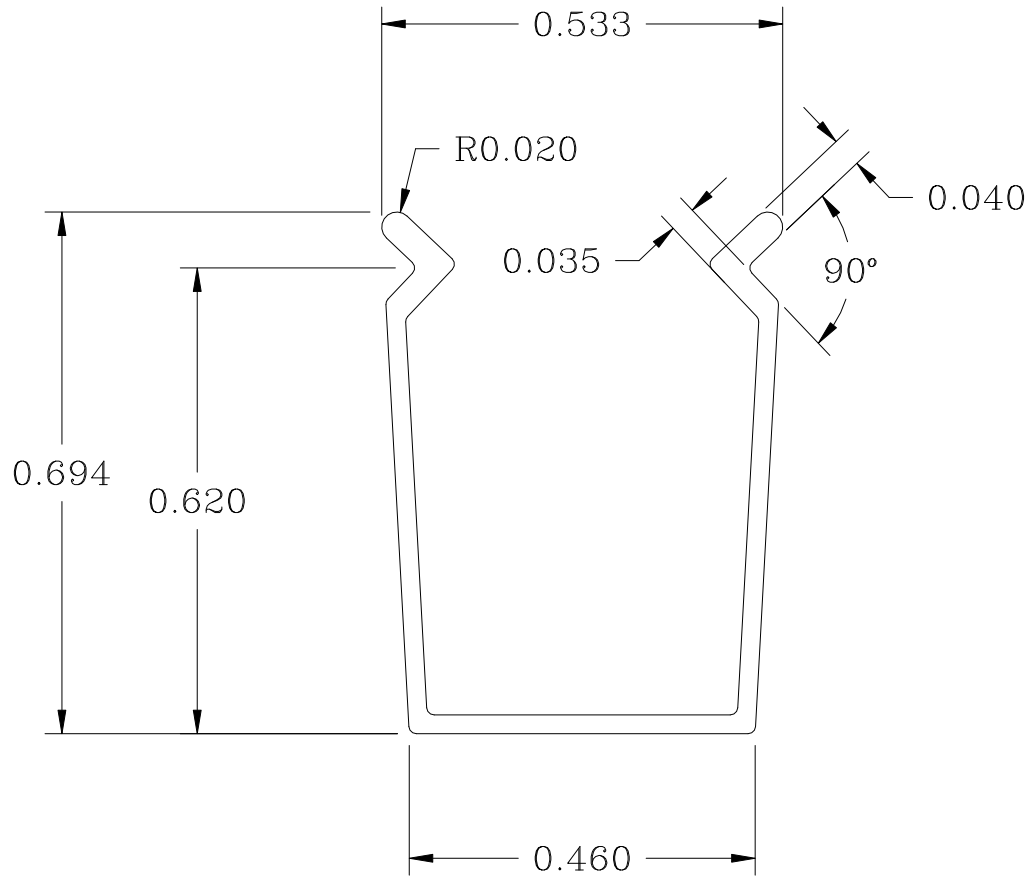

±1/64	FRACTION
±0.0100	X.X
±0.0010	X.XX
±0.0005	X.XXX
	X.XXXX
SUBTRACT 5 PTS. FOR EACH UNIT OF TOL. ANGLE ±1°	



Working Solutions in Aluminum, Plastics and Stainless Steel

Telephone: (253) 852-1399  
 Fax: (523) 520-9972  
 www.morseindustries.com

DR BY: ADAM FINCH	11/16/02	D	
DEPT. MANAGER:	___/___/___	C	
PART NAME: V25-7471		B	
FILE NAME: V25-7471	REV NO: -	A	