

| REV | ECO | DESCRIPTION | DATE | DRFT | CHKD |
|-----|-------|-------------|----------|------|------|
| C | 12488 | UPDATED | 10/01/14 | LS | BP |

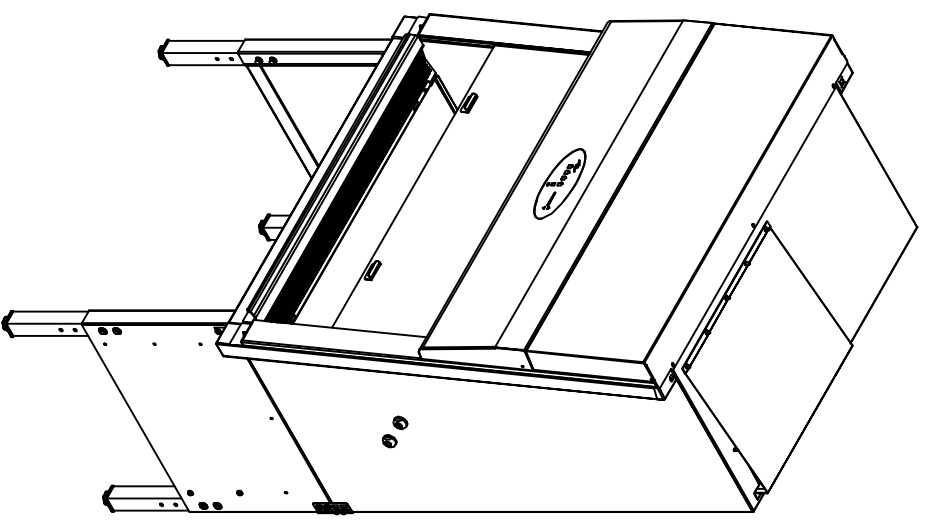

* OVERALL DIMENSIONAL TOLERANCE ±1/4 [6.35]
 ALL OTHER DIMENSIONS ±1/8 [3.17]

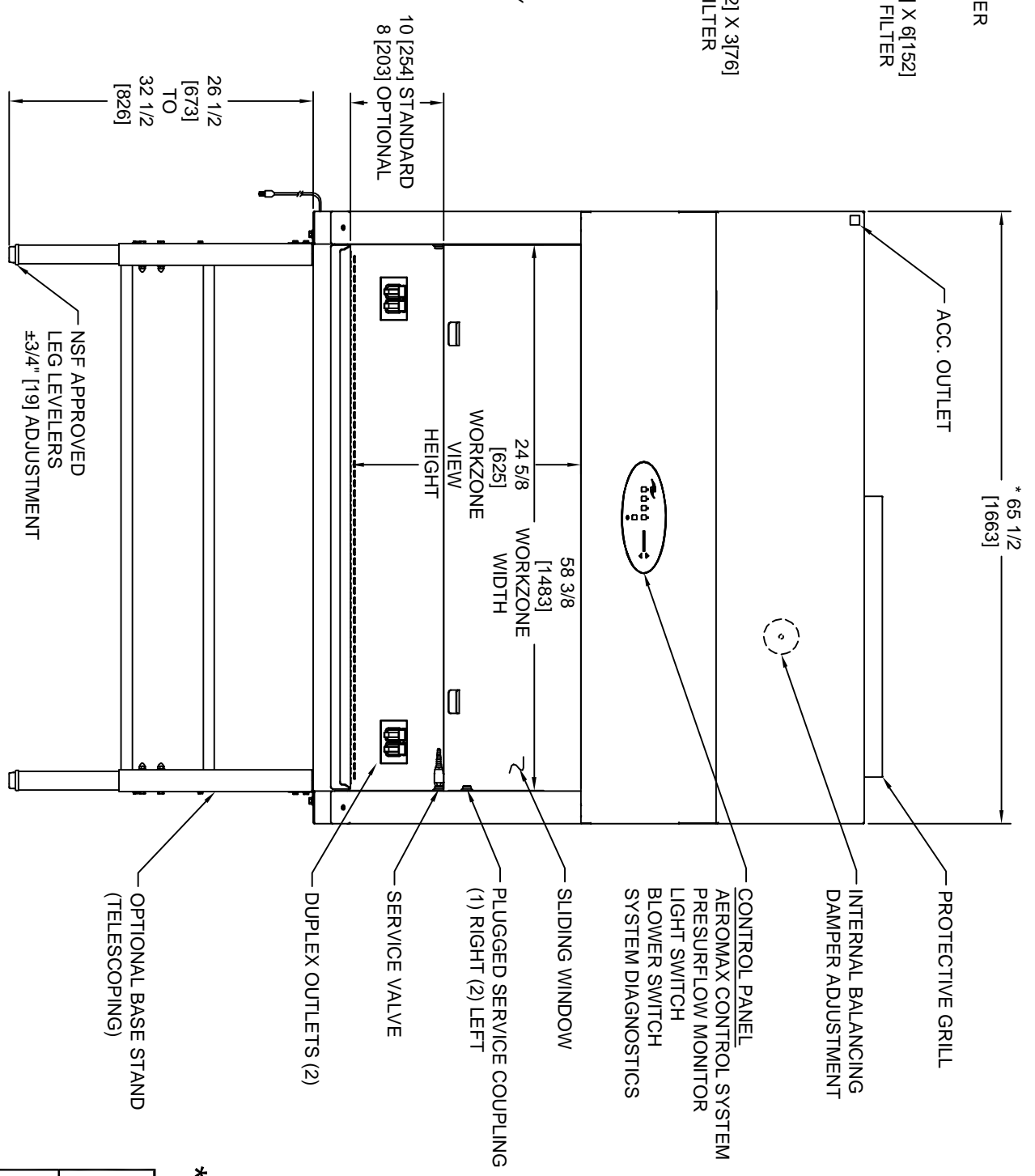
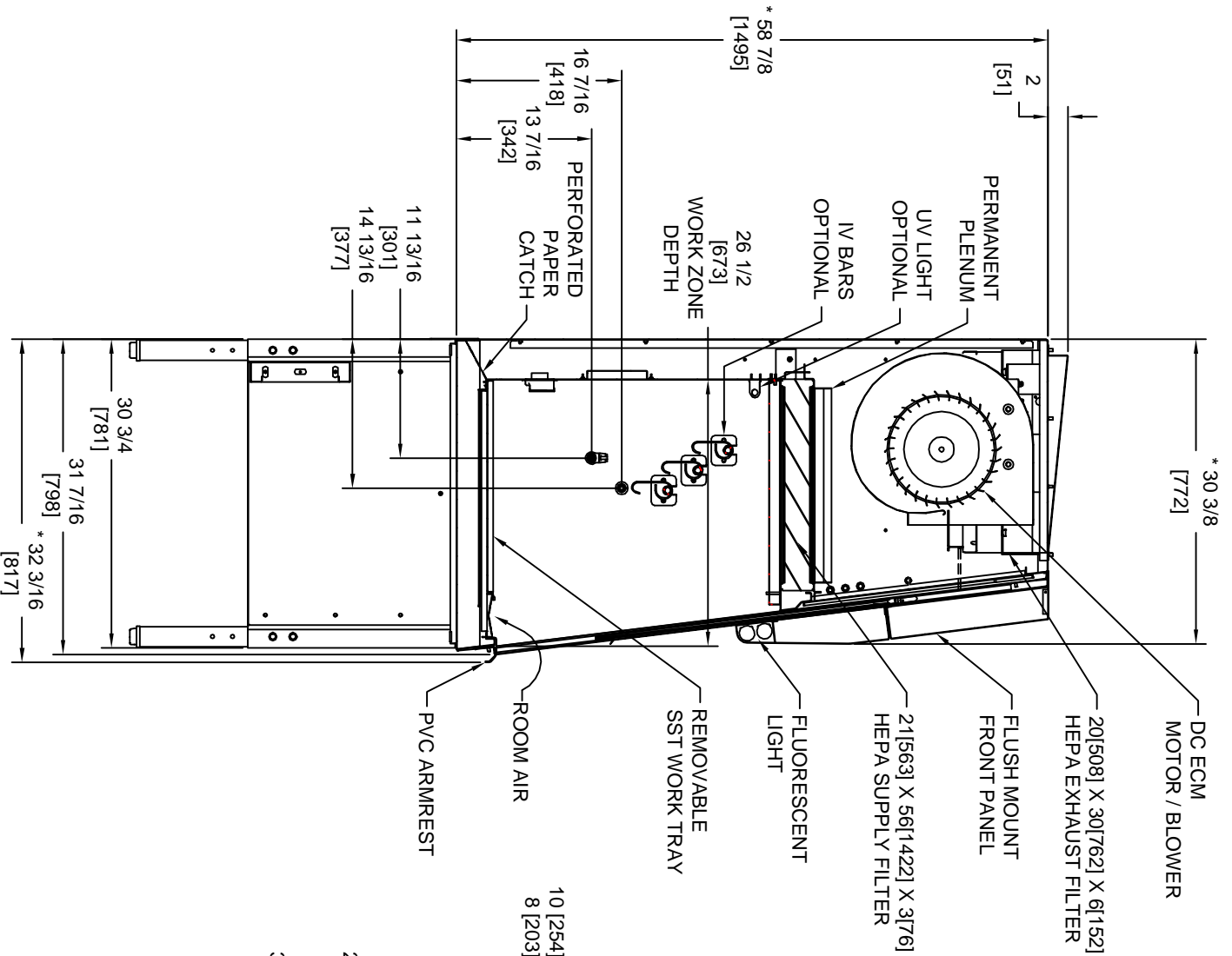
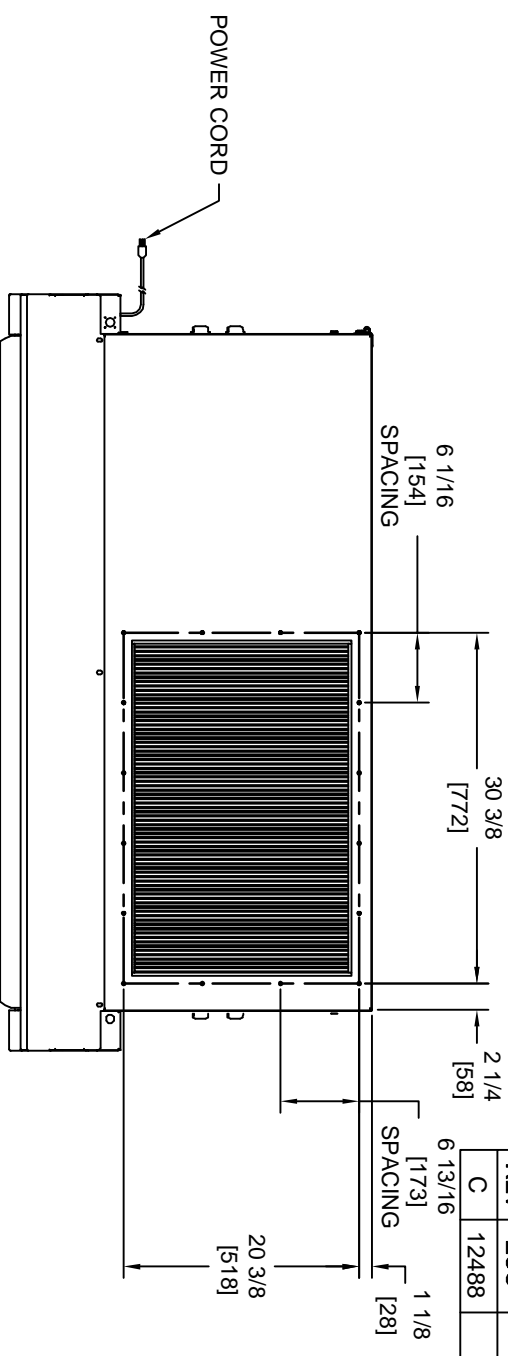

NU-540-500
 CLASS II, TYPE A2 (ENERGY SAVER)
 BIOLOGICAL SAFETY CABINET

INCH
 MILLIMETER

| | | | | | | |
|----------------|----|------------|------|----|-------|-----------|
| DFTM | LS | 12/16/2013 | CHKD | BP | SHEET | 1 OF 1 |
| DRAWING NUMBER | | | | | | BCD-16515 |
| | | | | | | C |