

*** Float Functions & Pump Index**

A	High Level Alarm / Lag Enable
B	Override Timer
C	Pump ON
D	Pump OFF
E	Redundant Off / Low Level Alarm

Recirculation Pumps: PF7510
 Discharge Pumps: PF
 Anoxic Return Pump: PF2005

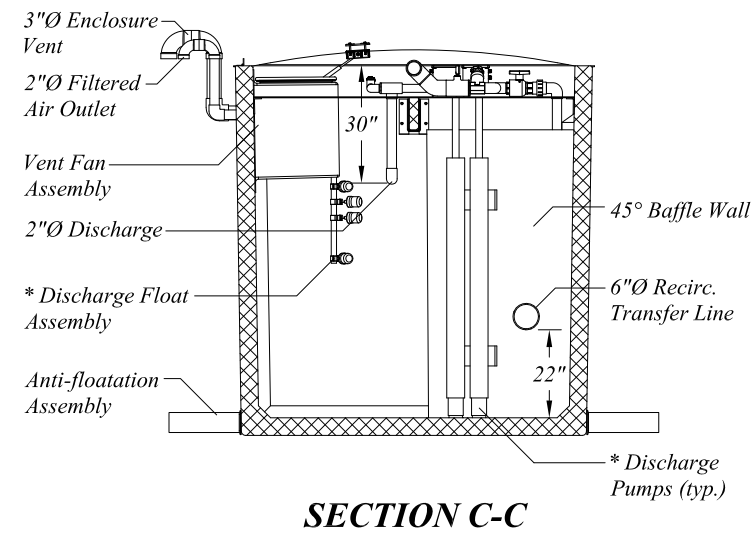
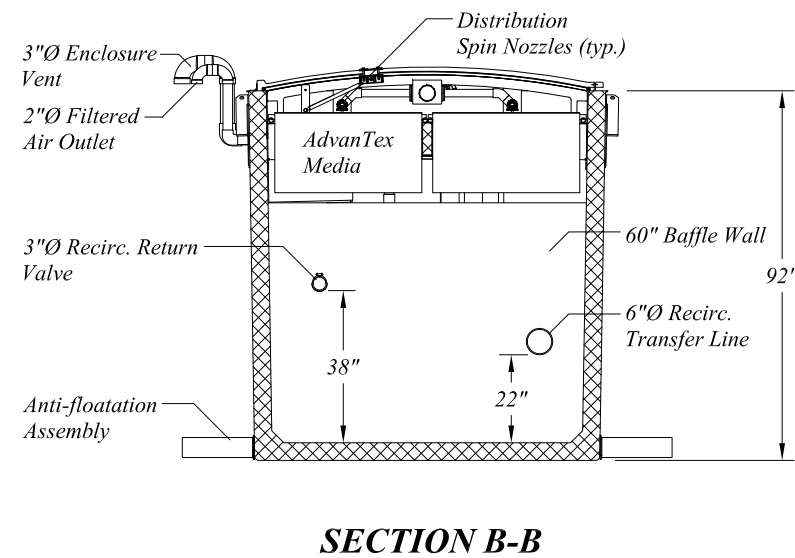
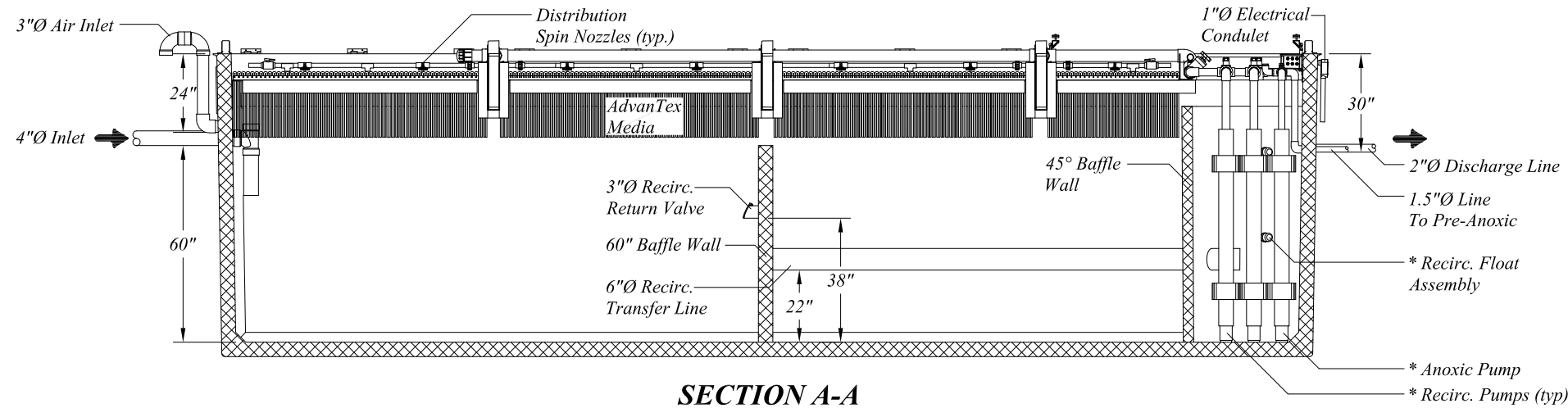

Customer Approval
 Signature: _____ Date: _____
 Customer Name: _____
 By this signature, Customer indicates that they have reviewed this Proposed System Configuration Drawing and found that it meets all of the designer's functional requirements and/or specifications.