

# AX20RTUV Treatment System - UV with Pump Discharge

Filter Tank Dry Weight: 900 lbs

## Design Notes

For residential strength waste up to 4 bedrooms.

Installation to be performed by an AdvanTex Authorized Installer only.

Start-up and service to be performed by an AdvanTex Authorized Service Provider only.

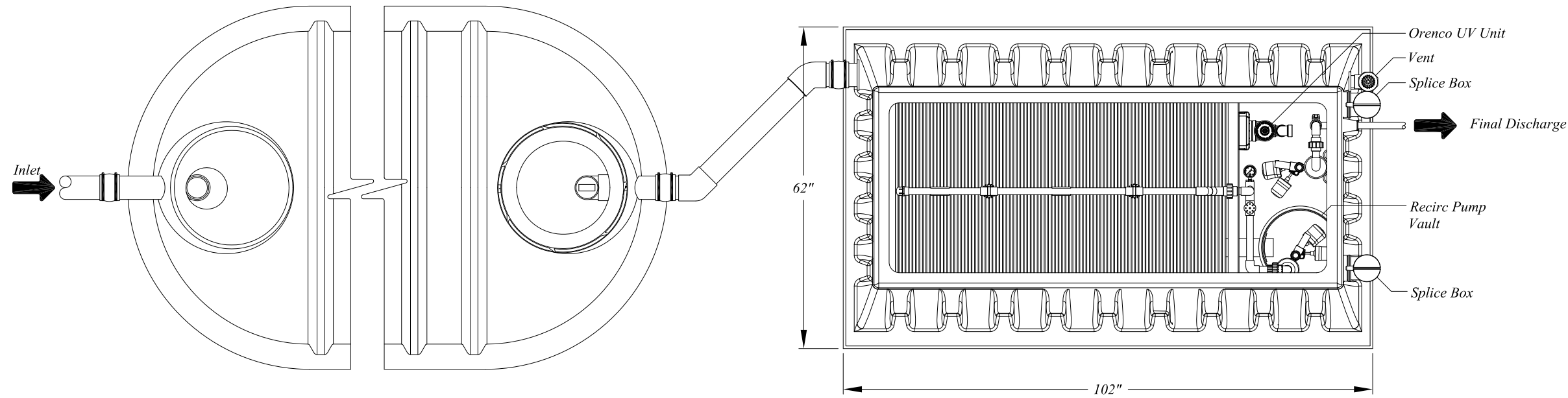

1000 gal. Primary Tank - Top View

AX20 800 gal. Recirc. Tank - Top View

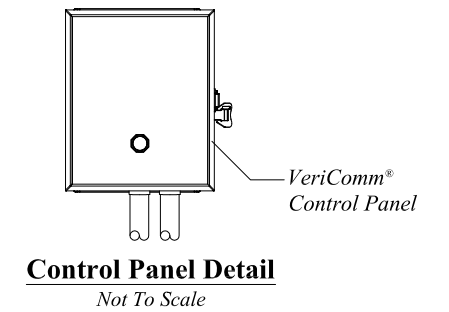

Control Panel Detail

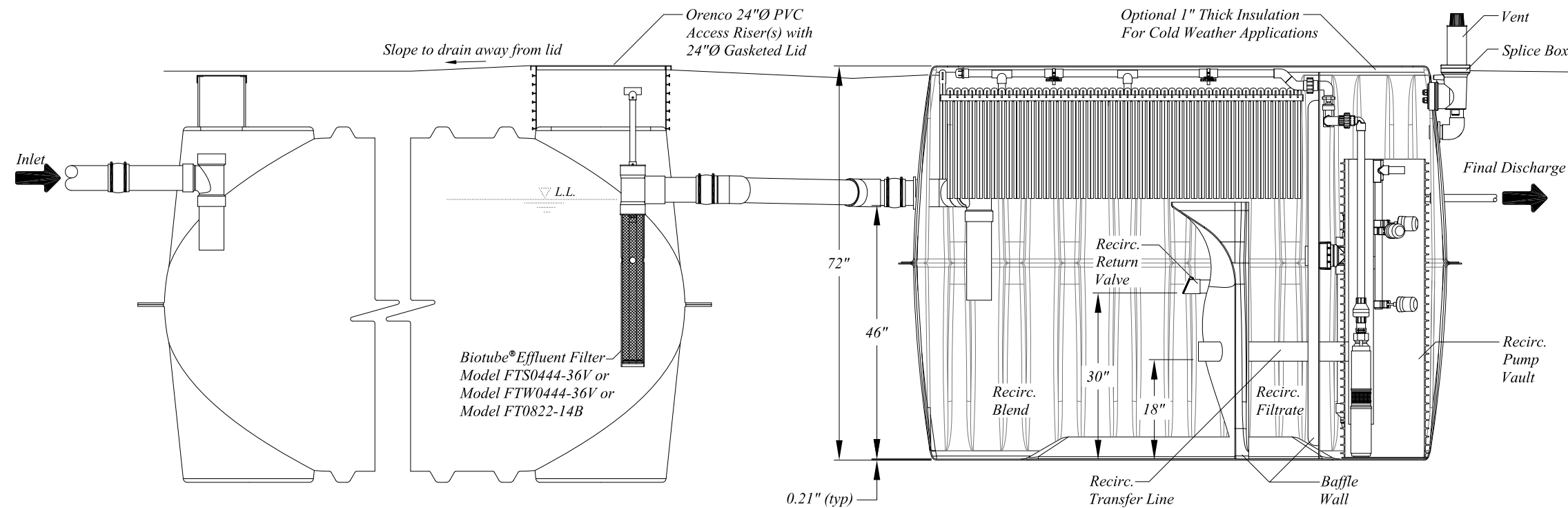

1000 gal. Primary Tank - Side View

AX20 800 gal. Recirc. Tank - Side View

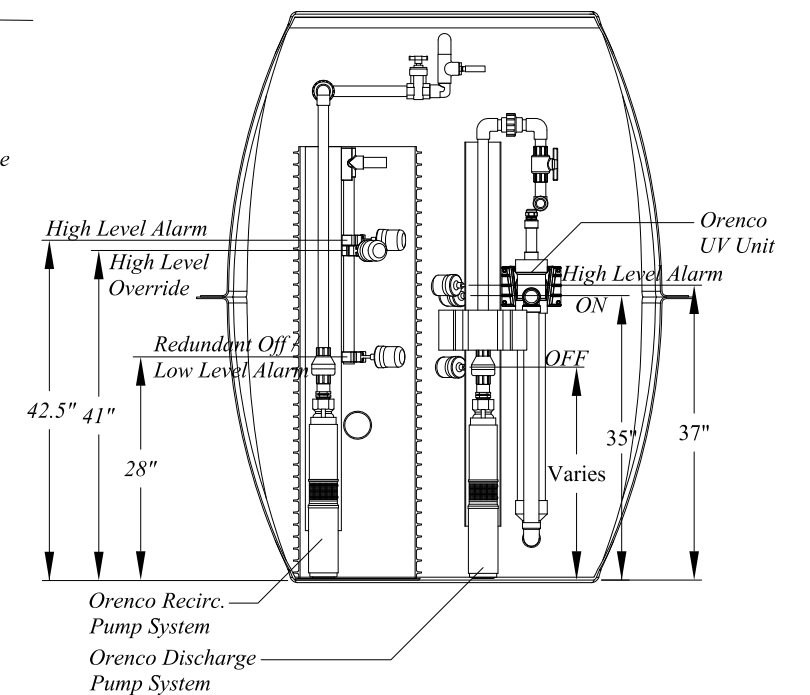

Discharge Chamber - End View

Copyright © 2013  
Orenco Systems®, Inc.

### UNAUTHORIZED CHANGES & USES

Orenco has prepared these drawings for use by the design engineer. Orenco will not be responsible or liable for unauthorized changes to or uses of these drawings. All changes to these drawings must be made in writing and must be approved by the design engineer.

PRODUCT CONFIGURATION DRAWINGS



Drawn By: BEN SMITH

Drawn For:

Project:

AX20RTUV Mode 1B

Title:

NDW-ATX-RT-STD-22

Scale: 1" = 2'-0"

Sheet: 1 OF 1

Rev: A-02

Date: 4/22/2013